

COMPUTERIZED SYSTEMS FOR REMOTE MONITORING
AND DIAGNOSTICS OF ELECTRIC POWER FACILITIESSergii Babak¹, Mykhailo Myslovych², Roman Sysak²

¹Research and Development Center of Emerging Technologies of the National Academy of Sciences of Ukraine, Kyiv, Ukraine, ²Institute of Electrodynamics of the National Academy of Science of Ukraine, Kyiv, Ukraine
sergii.babak@gmail.com; mysl@ied.org.ua; rsysak@ied.org.ua

© Babak S., Myslovych M., Sysak R., 2015

Abstract: Construction and practical use of computerized systems for remote monitoring and diagnostics of electric power facilities are discussed. The structure of information-measuring systems based on an unmanned aerial complex, that are designed to monitor thermal and nuclear power plants' environment is examined. The structure and algorithms of a multilevel system for monitoring and diagnostics of electric power facilities' equipment are discussed. The system allows the adaptation to a specific object hierarchy providing deep diagnostics of its elements, taking into account the severity of defects. The distinctive features of the proposed solutions are low cost, and high operation efficiency.

Key words: diagnostics, multilevel system, background radiation, environment.

1. Introduction

Today, in the energy complex of Ukraine, according to various estimates [1], 70–90 % of the main and auxiliary equipment is worn. Under these conditions, the further use of energy-intensive, and in some cases extremely dangerous equipment, e.g. nuclear power plants (NPP) requires the development of special methods and means that allow such operation and at the same time ensure the required level of reliability and security. Among them, the most effective methods are those of nondestructive control, monitoring and diagnostics of electric equipment.

Recently, thanks to new information technologies (including Smart Grid conception) and the Internet, it is possible to realize the methods and tools for monitoring, control and diagnostics of power facilities at new level that allows diagnostic information to be obtained with greater precision and reliability.

It is also necessary to note the appearance of jobs connected with creation of expert systems for technical diagnostics that are capable to process not only quantitative data but also different sorts of knowledge.

The technological and software-hardware means mentioned above provide an opportunity of proceeding to the establishment of information-measuring diagnostic systems, through which it would be possible to perform remote monitoring, control and diagnostics of energy

facilities' equipment. This especially concerns the objects or their components and elements, with which a direct contact of service personnel while measuring diagnostic signals is difficult or impossible. These objects include the equipment of NPP reactors, hydro and turbo generators, converters, aerial electric power lines (EPL), fuel and lubricants tanks, boiler houses etc.

The main objective of this paper is to build structural-functional schemes and discuss some peculiarities of practical application of information-measuring systems (IMS) for remote monitoring, control and diagnostics of energy facilities. As good cases in point, the paper considers the problem of constructing a structure of such IMS and their application to solve the problem of environment control in NPP operation areas, as well as the multilevel remote diagnostics system of electric power facilities built within Smart Grid conception and designed to solve a wide range of diagnostic problems.

2. Complex for remote monitoring, control and diagnostics of energy facilities

The first of the mentioned problems can be solved effectively and at comparatively low cost by using an unmanned aerial complex (UAC) to monitor the environment in NPP location areas. This complex allows remote video surveillance and photography of an underlying surface in inaccessible places or periodic control areas, as well as measurement of an exposure dose in airspace [2].

A monitoring complex is originally developed as a complete system, consisting of a number of subsystems (Fig. 1), and including:

- a) a control station consisting of an operator's workplace and software that enables an operator to control the complex as a whole;
- b) an unmanned aerial vehicle (UAV) that carries payload equipment of various types;
- c) a communication system that transmits control commands from the control station to the UAV, as well as transmits useful information from the UAV to the ground control station in real time;
- d) additional equipment that is designed for providing technical support for the research done.

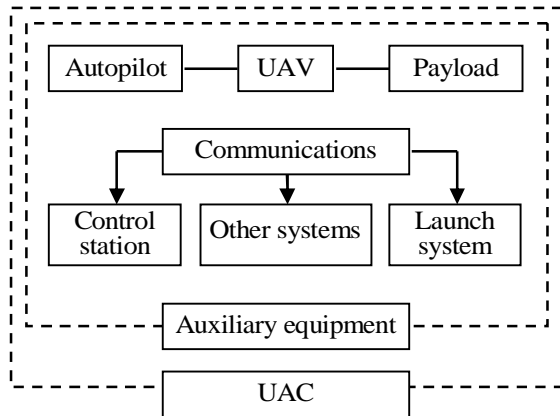

Fig. 1. Block diagram of an unmanned aerial complex.

UAVs have a significant degree of artificial intelligence automation. They can have a “dialogue” with the operator being at the ground control station and transmit such data as optical or thermal area images, supported by primary information about the location of UAV – its altitude, heading, speed, gradient etc.

For the background radiation (exposure dose rate – EDR) to be measured, there is a measurement system which allows automatic determination of the EDR in given spatial coordinates accompanied by simultaneous detection of a longitude, latitude and altitude of the measurement location [2]. Besides, the application of on/off switching of the information recording can be performed both by manual commands from a remote control unit and by autopilot commands. The system is based on a single-chip “ATXmega” RISC-architecture microcomputer produced by Atmel, which is a matching link between individual blocks, and controls its functions as a whole, according to the recorded program.

Its basic function is measuring the EDR of gamma radiation. Geiger-Muller counter is a proportional counter of ionizing radiation particles. The SI22B counter applied in UACs is capable of detecting mainly gamma rays, to a much lesser extent – beta particles, and is hardly sensitive to alpha particles. The number of events concerning the registration of ionizing radiation is directly proportional to the EDR. Thus, the EDR may be calculated as the number of current pulses from a counter per time unit. However, taking into account that the registration events are random in time, especially at low EDR, a mathematical filtration by the method of linearly weighted moving average is used for smoothing the measurement results. Furthermore, to reduce the scatter at a low-degree filtration, a parallel connection of two Geiger-Muller SI22G counters in one outer sealed unit is chosen.

3. Multilevel monitoring and diagnostics system for electric power facilities

In order to determine an actual condition of electric power facilities equipment for, it is necessary that either

periodically or in case of some predefined events, certain diagnostic signals be measured and analyzed, and diagnostic decisions be made according to certain algorithms. In the conditions of electric power facilities which are likely to be dangerous to human life and health, it would be desirable that the operations mentioned be performed with a minimum staff involvement. Thus it is necessary that such processes as acquisition of information, processing of measurement results, transfer of those results for summarizing and displaying be ensured as full automation as possible.

Any complex technical object could be presented as a hierarchical structure. In particular, for the electric part of a power plant, we can mark out the following hierarchy levels:

- an electric power plant as a whole;
- electric machinery (generators, engines, pumps, converters);
- a structural unit (stator and rotor windings of rotating machinery, bearing assemblies, magnetic circuits, body, cooling system, foundation);
- construction elements (individual parts that make up the structural units).

Studying the elements located at the lowest hierarchy level gives necessary information on the defect types, reasons and symptoms. That forms the basis for the construction of diagnostic models, and choice of diagnostic signals and parameters [3].

Taking into account a large number of elements that are located at the lowest hierarchy level, it becomes obvious that the development of a diagnostic system that fully covers all possible defects and their combinations is an extremely difficult technical problem. On the one hand, it is necessary for the system to be provided with some measuring equipment; on the other hand, significant computing capacities are required to process a huge information massive. As a result, the cost of such a diagnostic system could exceed the cost of the basic equipment, and the development of the diagnostic system could have no sense from the economic point of view. The following ideas could contribute to the solution of this problem: a hierarchical structure of the diagnostic system, classification of defects according to their importance for an energy facility to operate, and decentralization of computing resources. Let us discuss these ideas in more detail.

At the stage of the system structure design, a list of the defects to be detected by the diagnostic system should be clearly defined. Additionally, the construction elements in which those defects could arise should be identified. These very construction elements will be provided with measuring equipment designed for obtaining diagnostic signals. This measuring equipment represents the lowest level of the diagnostic system.

At the level of structural units, a separate processing module will be installed to convert an analogue signal to a digital one and preprocess the measurement information obtained from the structural elements belonging to the unit mentioned. This processing module could be based either on a microcontroller or on a low power industrial computer running a special software. The main objective of this module is to perform periodical measurement of diagnostic signals and preliminary assessment of actual technical status of each of the structural elements belonging to its hierarchy (interim analysis). In most cases, there will be no significant deviation of the actual elements status from the norm, and therefore there will be no need to transfer information to a higher level of hierarchy. If there are significant deviations from the norm (a high degree of defect criticality), the data preprocessing module should transmit the information to a higher level of the system hierarchy where a more detailed analysis of the data can be done.

In a general case, an algorithm of this module operation, depending on the results of an interim analysis, should implement the following data exchange logic with a higher hierarchical level of the diagnostic system:

- do not transmit any information at all – if there is no deviations from the normal status;
- issue a warning signal – if the detected deviations are considered insignificant;
- transmit the measured information to a higher level of hierarchy for a complete analysis – if the detected deviations are considered significant;
- issue an alarm signal to be immediately responded – if critical deviations are identified.

The module installed on the level of an electrical machine is intended for performing a deep analysis of the measured diagnostic signals which have been transferred from the lower-level modules. All the information about the actual state of the electrical machine is collected in this module and can be transferred by request to a higher level of the diagnostic system.

Such an approach to the system development provides an opportunity to simplify its structure, reduce the amount of information processed by the system and transferred between its hierarchical levels. The cost of the system could be reduced, and the available computing resources could be reallocated to perform more critical functions.

Given the foregoing, the functions' distribution between diagnostic system's modules belonging to different hierarchical levels is as follows:

- Construction elements level: initial selection and diagnostic signals preparation (diagnostic signals measurement, their amplification, analogue filtration and converting into digital form);
- Construction nodes level: preliminary mathematical processing and intermediate diagnostic decision-

making (simple algorithms, which do not require significant computing resources; information separation by defects criticality degree); signaling to a higher level if defects are identified; accumulation of minor amounts of measurement data and its transfer to a higher level (at an appropriate request);

- Electrical machinery level: accumulation, complete processing and deep data analysis, rapid response to alarms from a lower level, diagnostic decision-making on electric machinery as a whole, statistical data archiving, reliability forecast and assessment of residual life of equipment, repairs planning; data presentation to users.

Generalized structure of such system is shown on Fig. 2. It includes both wired and wireless measurement channels that allow data acquisition from rotating parts of the machines.

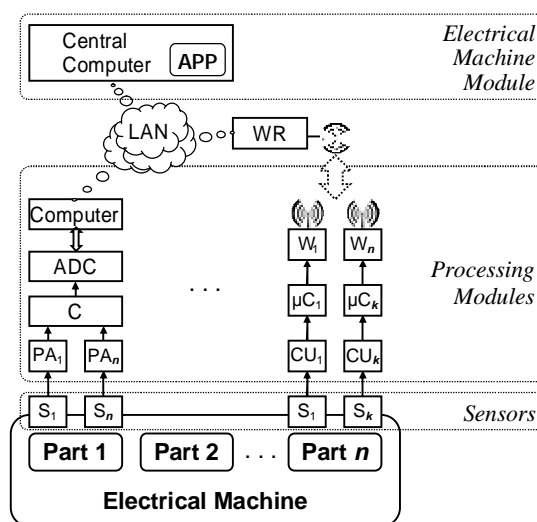

Fig. 2. Structure of a multilevel system for technical diagnostics of electrical machines: *S* – sensor; *PA* – pre-amplifier; *C* – commutation device; *ADC* – analog-to-digital converter; *CU* – conversion unit; *µC* – microcontroller; *W* – wireless communication unit; *WR* – wireless router; *APP* – application package for data analysis, diagnostic decision making, assessment of residual life; *LAN* – local area network.

The proposed system requires specific software to be installed in every of its modules. The architecture and functions performed by those programs depend on the level in the system's hierarchy where the module operates. Processing modules (level 2) are usually based on computers with low performance which have a limited amount of primary storage (Random Access Memory) and data storage capacity. They are running Linux-like operating systems. On the other hand, the modules designed for Electrical Machine level are usually based on more powerful computers which have enough resources to run Windows (that provides a wide range of user-friendly applications) and perform complex computing.

Fig. 3 shows a high-level functional diagram of the software. The modules run dedicated processes (DiagMon for 2nd level, DiagMaster for 3rd level), which continuously collect data from the attached modules of the lower level. That information is the basis for diagnostics, and its results are used by another process, Alarmer, which detects violations and alarms as needed.

An efficient communication between different platforms could be achieved by different means; in this system, Web Service (WS) technology has been chosen due to its great flexibility and ease of implementation.

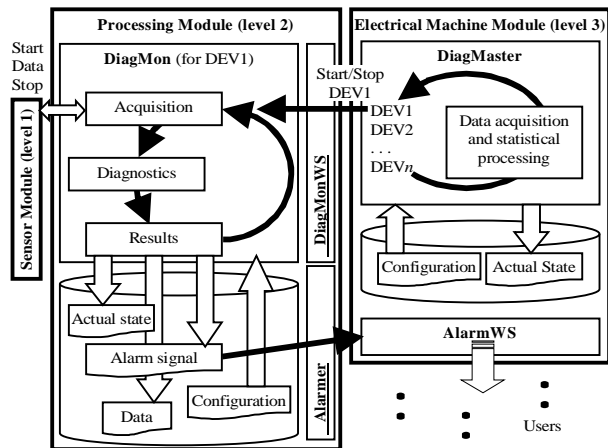

Fig. 3. Functional diagram of the modules' software.

6. Conclusion

The remote information-diagnostic complex using UAC, as well as an environmental radiation monitoring system in the areas of NPP location have been developed on the basis of modern information technologies. The proposed structure of a multilevel system for diagnostics and monitoring of actual status of electric power facilities equipment ensures measurement and transmission of diagnostic information without involving an operator, and provides detection, localization and classification of critical defects considering the hierarchical structure of typical power facilities.

References

- [1] V. V. Kuzmin, A. L. Livshits, and V. S. Shpatenko, "Lowcost and energy-saving technologies of turbo-generators rehabilitation – the basis of Ukraine technical reequipment", *Electromechanical and Energy Saving Systems*, vol.14, no. 2, pp. 90–92, 2011. (Russian)
- [2] S. Babak, "Radiation monitoring of environment using unmanned aerial complex", *The Advanced Science Journal*, no. 12, pp. 41–44, 2014.
- [3] M. Myslovych and R. Sysak, "On some peculiarities of design of intelligent multi-level systems for technical diagnostics of electric power facilities", *Tekhnichna elektrodynamika*, no. 1, pp. 78–85, 2015. (Ukrainian)

КОМП'ЮТЕРИЗОВАНІ СИСТЕМИ ДИСТАНЦІЙНОГО КОНТРОЛЮ І ДІАГНОСТИКИ ОБ'ЄКТІВ ЕЛЕКТРОЕНЕРГЕТИКИ

Сергій Бабак, Михайло Мислович, Роман Сисак

Розглянуто особливості побудови та практичного використання комп'ютеризованих систем дистанційного контролю і діагностики об'єктів електроенергетики. Наведено структуру інформаційно-вимірювальної системи на основі безпілотного авіаційного комплексу, яка призначена для контролю довколишнього середовища в районах розташування теплових та атомних електростанцій. Розглянуто структуру та алгоритми роботи багаторівневої системи моніторингу та діагностики стану обладнання об'єктів електроенергетики, яка може адаптуватися до ієрархії конкретного об'єкта, забезпечуючи глибоку діагностику стану його елементів з урахуванням ступеня критичності дефектів. Запропоновані рішення відрізняються невеликою вартістю, але при цьому високою ефективністю роботи.

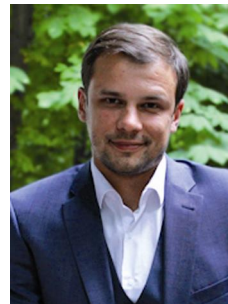

Sergii Babak – employed with Research and Development Center of Emerging Technologies of National Academy of Sciences of Ukraine. He graduated from Napier University, Great Britain, in 1999 (BSc) and Kyiv National Economic University in 2000 (MSc). In 2004 he defended his Ph.D. thesis. His scientific interests are information-measuring systems based on unmanned aerial complexes.



Mykhailo Myslovych – Head of Department at the Institute of Electrodynamics of National Academy of Sciences of Ukraine. He graduated from Kyiv Polytechnic Institute, Ukraine (Industrial electronics) in 1975. In 1985 he defended his Ph.D. thesis, and in 1995 his Doctoral thesis at the Institute of Electrodynamics of NAS of Ukraine.

He is a laureate of the State Prize of Ukraine in Science and Technology (2005). Scientific interests: mathematical modeling, technical diagnostics, random processes, mathematical statistics, signal processing.



Roman Sysak – Senior Researcher at the Institute of Electrodynamics of National Academy of Sciences of Ukraine. He graduated from Ternopil State Technical University, Ukraine (electronic engineer) in 1997. In 2001 he defended his Ph.D. thesis at the Institute of Electrodynamics of NAS of Ukraine in the specialty "Information-measuring systems".