

METHODS OF PARAMETRIC SENSITIVITY REDUCTION
OF A FIELD-ORIENTED CONTROLLED DRIVE

Igor Smetana, Andriy Lozynsky, Valeriy Misyurenko

Lviv Polytechnic National University, Lviv, Ukraine
IGwest2011@gmail.com, lozynsky@polynet.lviv.ua

© Smetana I., Lozynsky A., Misyurenko V., 2015

Abstract: The well-known problem of parametric sensitivity of a field oriented controlled induction motor drive is considered. The analytical method is offered for parametric sensitivity investigation. Using the results obtained with this method and results obtained by the mathematical models, conclusions are drawn and recommendations for the parametric sensitivity reduction are made. The effective method for the identification of IM parameters at a standstill is proposed. The optimal structures of Artificial Neural Networks are proposed for the flux identification in the FOC drive in which the parametric disturbances occur.

Key words: field oriented control, sensitivity, identification, estimator, neural networks, induction motor.

1. Introduction

The field oriented controlled (FOC) systems are mostly used in up-to-date inverter fed induction motor (IM) drives because of their high energy efficiency and dynamic properties. But it is known that there are some drawbacks of the FOC drives that result in non-optimal functioning of the whole system especially when the parametric disturbances are present. To avoid those problems, many approaches have been proposed recently [1, 2]. For example, besides conventional Direct Field Oriented Control (DFOC), some new vector control schemes were proposed, such as Indirect Field Oriented Control (IFOC), Direct Torque Control (DTC), FOC with hysteresis regulators, and others [3, 4]. Most of the above mentioned approaches were directed towards the improvement of the identification block identifying drive parameters and state variables [1-4]. Taking into consideration a great amount of the different FOC schemes, the important factor is the influence of different drive parameters or state variables on the system characteristics [5]. In other words, to design the FOC system, one should know to which factors the drive is most sensitive. For determining that, the sensitivity analysis is necessary. Moreover, the analytical evaluation of the common parametric sensitivity is important to compare different FOC schemes of the IM drive. For this purpose we propose using the L_2 -sensitivity method [6], described in Chapter 2. The increasing of accuracy of the identification of parameters and state variables is another important task.

For the IM parameters identification we propose using the method of test signals in frequency domain when motor is at standstill [7, 8] and Artificial Neural Networks (ANN) estimators for flux linkage identification (Chapters 3, 4) [9, 10].

2. Sensitivity investigation of the FOC systems

The sensitivity method based on L_2 -sensitivity theory [6] allows analytical calculating the value of parametric sensitivity regardless of the number of changed parameters. Thus, for transfer function (TF) in frequency domain:

$$H(s) = C \cdot (s \cdot I - A)^{-1} \cdot B, \tag{1}$$

the new TF could be written as follows:

$$\begin{aligned} \hat{H}(s) &= H(s) + \Delta H(s) = \\ &= (C + \Delta C) \cdot (s \cdot I - (A + \Delta A))^{-1} \cdot (B + \Delta B) \end{aligned} \tag{2a}$$

The sensitivity value S_p to one of the parameters could be expressed as:

$$\begin{aligned} S_p &= \frac{S_{\Delta H}^2}{S_p^2} = \\ &= \frac{\int_D \left| \frac{\partial H(jw)}{\partial p} \right|^2 \cdot S_p^2 \cdot dw}{S_p^2} = \int_D \left| \frac{\partial H(jw)}{\partial p} \right|^2 dw \end{aligned} \tag{2b}$$

where $S_{\Delta H}^2$ is the rms of transfer function error; S^2 is the rms of parameter; D is a system frequency range.

The common parametric L_2 -sensitivity can be expressed as follows:

$$\begin{aligned} S &= \frac{S_{\Delta H}^2}{S^2} = \left\| \frac{\partial H(s)}{\partial A} \right\|_2^2 + \left\| \frac{\partial H(s)}{\partial B} \right\|_2^2 + \left\| \frac{\partial H(s)}{\partial C^T} \right\|_2^2 = \\ &= \left\| G^T(s) \cdot F^T(s) \right\|_2^2 + \left\| G^T(s) \right\|_2^2 + \left\| F(s) \right\|_2^2. \end{aligned} \tag{3}$$

where

$F(s) = (s \cdot I - A)^{-1} \cdot B$, $G(s) = C \cdot (s \cdot I - A)^{-1}$; $\frac{\partial H(s)}{\partial A}$ is the derivative of TF with respect to the matrix; $\|\bullet\|_2$ is a L_2 -norm of the matrix.

Using the proof demonstrated in [6], equality (3) could be rewritten as follows:

$$\mathbf{S} \equiv (\text{tr}[\mathbf{W}_0] + 1) \cdot (\text{tr}[\mathbf{K}_0] + 1) + \sqrt{2} \cdot \Delta \cdot \sum_{i=1}^{\infty} \text{tr}[\mathbf{W}_i] \cdot \text{tr}[\mathbf{K}_i], \quad (4)$$

where \mathbf{K} , \mathbf{W} are controllability Gramian and observability Gramian, correspondingly; Δ is a discretization period of matrix exponent approximation $e^{\mathbf{A} \cdot t} = e^{\mathbf{A} \cdot i\Delta}$; $i = 1, 2, 3, \dots$

The matrices \mathbf{K} and \mathbf{W} at $i = 0$ are expressed as:

$$\mathbf{K}_0 = \frac{1}{2 \cdot p \cdot j} \int_{-j\infty}^{j\infty} \mathbf{F}(s) \cdot \mathbf{F}^T(-s) \cdot ds = \int_0^{\infty} e^{\mathbf{A}t} \cdot \mathbf{B} \cdot \mathbf{B}^T \cdot e^{\mathbf{A}^T t} dt,$$

$$\mathbf{W}_0 = \frac{1}{2 \cdot p \cdot j} \int_{-j\infty}^{j\infty} \mathbf{G}^T(s) \cdot \mathbf{G}(-s) \cdot ds = \int_0^{\infty} e^{\mathbf{A}^T t} \cdot \mathbf{C}^T \cdot \mathbf{C} \cdot e^{\mathbf{A}t} dt.$$

Using the Lyapunov equations, \mathbf{K} and \mathbf{W} matrices at $i = 1, 2, 3, \dots$, could be calculated from the following system of equations:

$$\begin{aligned} \mathbf{A} \cdot \mathbf{K}_i + \mathbf{K}_i \cdot \mathbf{A}^T &= \\ &= -\frac{1}{2} \cdot \left(\mathbf{B} \cdot \mathbf{B}^T \cdot e^{\mathbf{A}^T \cdot i\Delta} + e^{\mathbf{A} \cdot i\Delta} \cdot \mathbf{B} \cdot \mathbf{B}^T \right), \\ \mathbf{A}^T \cdot \mathbf{W}_i + \mathbf{W}_i \cdot \mathbf{A} &= \\ &= -\frac{1}{2} \cdot \left(\mathbf{C}^T \cdot \mathbf{C} \cdot e^{\mathbf{A} \cdot i\Delta} + e^{\mathbf{A}^T \cdot i\Delta} \cdot \mathbf{C}^T \cdot \mathbf{C} \right). \end{aligned} \quad (5)$$

With the use of equations (4) and (5), two algorithms were developed for sensitivity evaluation either to separate parameter dissipation or common parametric L_2 -sensitivity [11]. They were realized for generalized simplified DFOC drive model both with PI and with hysteresis current regulators. In both cases the matrices \mathbf{A} , \mathbf{B} and \mathbf{C} were calculated. Also, the sensitivity to state accuracy of variables identification using feedback coefficients was calculated.

Table 1

№	IM parameter	Divergence of parameter	Sensitivity (rms of TF error) to one parameter in the FOC system			
			with PI current regulators		with hysteresis current regulators	
			Flux loop	Speed loop	Flux loop	Speed loop
1.	R_s, Ω	+0,21	0.523	49.26	≈ 0	≈ 0
2.	R_r, Ω	+0,32	64.28	90.07	9.46	≈ 0
3.	L_m, H	-0,0369	0.014	6.28	$2.8 \cdot 10^{-3}$	6.0607
4.	$L_{\sigma s}, \text{H}$	-0,0009	1.289	44.06	≈ 0	$3.62 \cdot 10^{-4}$
5.	$L_{\sigma r}, \text{H}$	-0,0013	1.222	48.81	$5.4 \cdot 10^{-4}$	1.0620

where $R_r, R_s, L_m, L_{\sigma s}, L_{\sigma r}$ are IM equivalent circuit parameters.

Table 2

№	FOC system	Sensitivity (rms of TF error) to state variables identification error				
		Flux loop		Speed loop		
		$\Delta k_{cur} = 20\%$	$\Delta k_{flux} = 20\%$	$\Delta k_{cur} = 20\%$	$\Delta k_{flux} = 20\%$	$\Delta k_{speed} = 20\%$
1.	with PI current regulators	15.41	18.36	101.78	642.30	11 321
2.	with hysteresis current regulators	102.11	1 117.6	321.79	24 277	108 513

$\Delta k_{cur, flux, speed}$ – state variable feedback errors

The results (see Tables 1, 2) achieved with the above-described algorithms confirm the correlation with parametric sensitivity, obtained experimentally [5]. Those results make it possible to suggest following hints:

- FOC systems with PI current regulators are more sensitive to parameter changing than the FOC systems with hysteresis regulators;
- FOC systems are the most sensitive to winding resistances;
- FOC systems with hysteresis regulators are more sensitive to state variables identification accuracy than the FOC systems with PI regulators;
- the flux loop makes great influence on speed loop sensitivity.

Assuming that, it is obvious that the most important tasks in the FOC systems consist in the increasing the accuracy of the identification of parameters and state variables.

3. Identification of IM parameters

As mentioned above, parameter identification is one of the important tasks in developing modern AC electric drives. This problem is solved by different methods. First of all, these are on-line methods for parameter identification described in [12, 13]. Such methods give good results in different conditions of system operation, but require large computational resources and speed sensors thereby increasing the complexity of the whole system. On the other hand, off-line algorithms also known as “self-commissioning” or “auto-test” are simpler and provide the values of constant parameters during operation. Some off-line identification algorithms in time-domain proposed in [14, 15] give satisfactory accuracy of machines parameters. But the use of the precise and expensive sensors is essential for them. Besides, it is also often necessary to make a no-load test, which is sometimes impossible because of technical conditions and process requirements.

For that reason the parameters identification methods in frequency-domain and at standstill of a motor are most suitable for solving this problem. Proposed in [7], our frequency-domain method operates at standstill without any additional mechanical devices and speed sensors. Only a current sensor with relatively high accuracy is required

here. For minimization of the influence of systematic and random errors on the results of identification, the method of least error squares was used.

The transfer function from phase voltage to current:

$$Y(j\omega) = \frac{i_{1a}(j\omega)}{u_{1a}(j\omega)} = \frac{1 + j\omega \cdot b_1}{a_0 + j\omega \cdot a_1 + (j\omega)^2 \cdot a_2} \quad (6)$$

has been applied in the proposed algorithm. With the coefficients of the known transfer function the motor parameters can be found as:

$$R_1 = a_0; R_2 = \frac{a_1}{b_1} - a_0; b_1 = \frac{L_2}{R_2};$$

$$a_2 = \frac{L_1 \cdot L_2}{R_2} - \frac{L_H^2}{R_2}; L_2 \approx L_1 = b_1 \cdot R_2;$$

$$L_H = \sqrt{L_1 \cdot L_2 - a_2 R_2}$$

To determine the unknown parameters in equation (6), the results of at least four transfer functions with different radian frequencies ω are necessary. From the transfer function, the error minimization leads to the equation:

$$Error \equiv \frac{1 + j\omega \cdot b_1}{a_0 + j\omega \cdot a_1 + (j\omega)^2 \cdot a_2} - Y(j\omega) = 0 \quad (7)$$

The conversion of equation (7) in matrix style for n frequencies yields:

$$\begin{pmatrix} Y(j\omega_1) & j\omega_1 \cdot Y(j\omega_1) & -\omega_1^2 \cdot Y(j\omega_1) & -j\omega_1 \\ Y(j\omega_2) & j\omega_2 \cdot Y(j\omega_2) & -\omega_2^2 \cdot Y(j\omega_2) & -j\omega_2 \\ Y(j\omega_3) & j\omega_3 \cdot Y(j\omega_3) & -\omega_3^2 \cdot Y(j\omega_3) & -j\omega_3 \\ Y(j\omega_4) & j\omega_4 \cdot Y(j\omega_4) & -\omega_4^2 \cdot Y(j\omega_4) & -j\omega_4 \\ \vdots & \vdots & \vdots & \vdots \\ Y(j\omega_n) & j\omega_n \cdot Y(j\omega_n) & -\omega_n^2 \cdot Y(j\omega_n) & -j\omega_n \end{pmatrix} \cdot \begin{pmatrix} a_0 \\ a_1 \\ a_2 \\ b_1 \\ \mathbf{q} \end{pmatrix} = \begin{pmatrix} 1 \\ 1 \\ 1 \\ \vdots \\ 1 \\ \mathbf{c} \end{pmatrix} \quad (8)$$

With the use of the method of least error squares, the vector \mathbf{q} of the unknown parameters can be calculated by the equation:

$$\mathbf{q} = (\mathbf{A}_{adj} \cdot \mathbf{A})^{-1} \cdot \mathbf{A}_{adj} \cdot \mathbf{c} \quad (9)$$

To implement the procedure of parameters identification, the frequencies w_i as well as real and imaginary parts of stator impedance are necessary. They could be calculated as follows:

$$w_i = 2p f_i;$$

$$\text{Re}\{Y(w_i)\} = \frac{\max\{I_{sa}(w_i)\}}{\max\{U_{sa}(w_i)\}} \cos(-g_i); \quad (10)$$

$$\text{Im}\{Y(w_i)\} = \frac{\max\{I_{sa}(w_i)\}}{\max\{U_{sa}(w_i)\}} \sin(-g_i)$$

where g_i is a phase shift between stator voltage and current. The algorithm of obtaining $\max\{I_{sa}\}$, $\max\{U_{sa}\}$ and g given in [8].

To reduce the error occurred due to matrix operations with relatively large differences between values of elements, we applied the stator resistance pre-estimation [8]. Taking into account proposed modification, the matrix equation (8) becomes as follows:

$$\begin{pmatrix} j\omega_1 \cdot Y(j\omega_1) & -\omega_1^2 \cdot Y(j\omega_1) & -j\omega_1 \\ j\omega_2 \cdot Y(j\omega_2) & -\omega_2^2 \cdot Y(j\omega_2) & -j\omega_2 \\ j\omega_3 \cdot Y(j\omega_3) & -\omega_3^2 \cdot Y(j\omega_3) & -j\omega_3 \\ \dots & \dots & \dots \\ j\omega_n \cdot Y(j\omega_n) & -\omega_n^2 \cdot Y(j\omega_n) & -j\omega_n \end{pmatrix} \cdot \begin{pmatrix} a_1 \\ a_2 \\ \mathbf{q} \end{pmatrix} = \begin{pmatrix} 1-R_1 \cdot Y(j\omega_1) \\ 1-R_1 \cdot Y(j\omega_2) \\ 1-R_1 \cdot Y(j\omega_3) \\ \dots \\ 1-R_1 \cdot Y(j\omega_n) \end{pmatrix} \quad (11)$$

Using equations (11) and tests for more than four frequencies the asynchronous machine parameters can be calculated.

4. Identification of the flux linkage using ANN

The conventional approaches to the stator/rotor flux vector estimation are those based on the back e.m.f. integration (Voltage model estimators) or using stator and rotor currents (Current model estimators). There are also many combinations of these two methods. Unfortunately, FOC systems with those conventional estimators (CE) are sensitive to the possible deviations of parameters. To avoid this situation and to improve the identification of state variables, the use of ANNs is proposed. Having good approximation and filtering properties, estimators based on ANN allow neglecting the influence of the identification error on the control algorithm [16, 17]. Besides, it is well-known that the ANN can overcome parameter variations working as an adaptive identification system. At the same time, the ANN properties mostly depend on the correct choice of ANN architecture and the correct performance of a training process. Nevertheless, there is no standard method for solving those problems yet, and the scientists use their own experience during the ANN synthesis.

There are two types of ANNs often used in FOC drives: Feed-forward neural networks (FFNN) and Recurrent neural networks (RNN). In spite of good approximation properties of the FFNN, the use of the RNN is recommended for the dynamic nonlinear systems identification [18, 19]. It is known that the recurrent ANNs allow taking into account the network output variation in time domain. The most popular RNN structures are Elman and Hopfield Networks. Unfortunately, not much attention

is paid to the RNN application for the flux identification in the DFOC drive system.

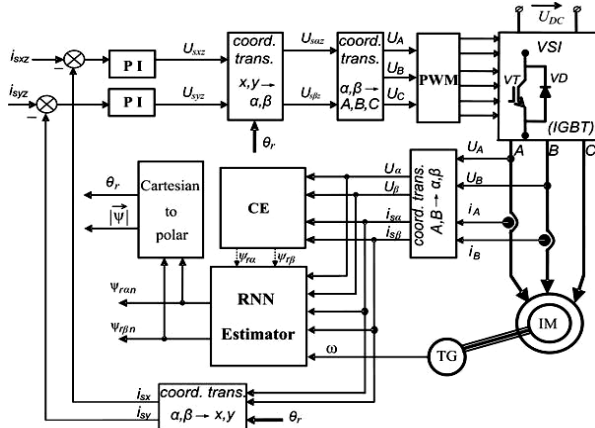

Fig. 1. Generalized block diagram of DFOC system.

In [10] we have shown the design of the optimal RNN structure for the rotor flux vector identification in conventional DFOC drive system (see Fig. 1). The conventional DFOC drive consist of 3-phase induction motor (IM), voltage source inverter (VSI) with PWM (or SVPWM) voltage modulation technique, encoder or tacho-generator (TG), PI/PID-regulators, estimators and coordinates transformation blocks. To estimate the angle θ_r and the amplitude $|\psi_r|$ of the rotor flux vector, its α - β components ψ_{ra} and ψ_{rb} are needed. But the information from CE could be affected by the variation of motor parameters. In the case of RNN estimator, all the possible parameter changes are included into a training data set. The RNN vectors are formed as follows:

$$\begin{cases} \mathbf{u}(k+1)\{R_r, R_s, L_m, L_{Ss}, L_{Sr}\} = [U_a, U_b, i_{sa}, i_{sb}]^T_{k+1}, \\ \mathbf{y}(k+1)\{R_r, R_s, L_m, L_{Ss}, L_{Sr}\} = [y_{ra}, y_{rb}]^T_{k+1}, \\ \mathbf{y}^*(k+1)\{R_r, R_s, L_m, L_{Ss}, L_{Sr}\} = [y_{ran}, y_{rbn}]^T_{k+1}. \end{cases}$$

Taking into account the experience of ANN design using FFNN [9], we decided to remove the voltage signals $U_{sa} \cdot U_{sb}$ from the input vector to increase the RNN stability. It could be explained by the inconsistency between the voltage signals in the control system and the real phase voltages applied to the motor windings. Besides, to provide fast training and noise filtering, the modified training procedure was applied (RNN).

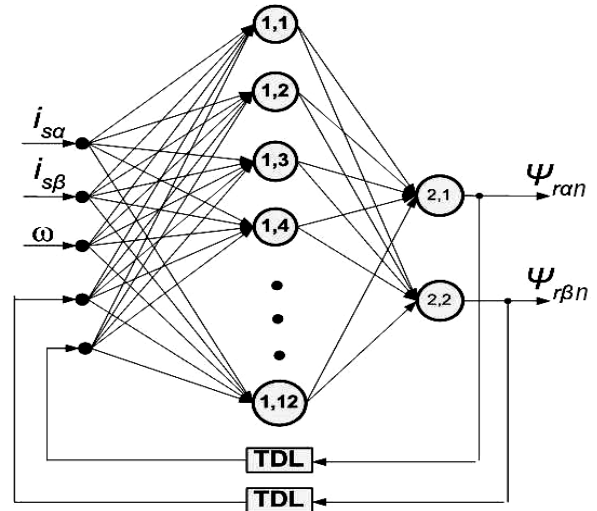
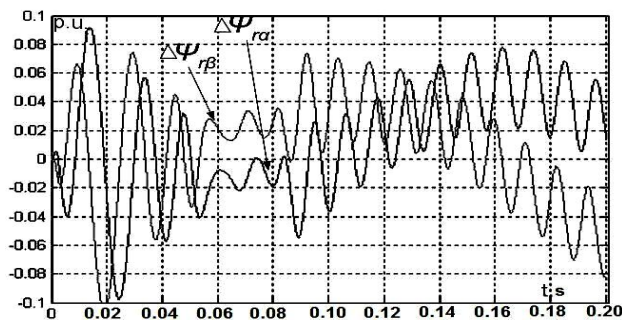
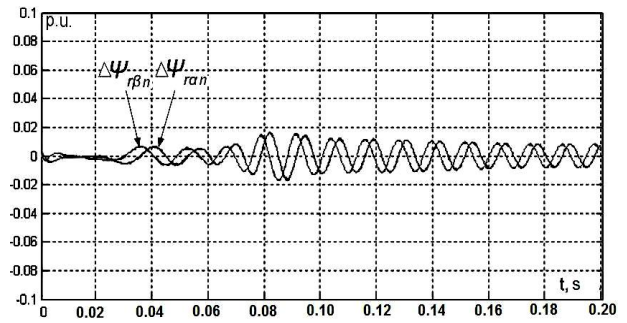

Fig. 2. Optimal RNN structure.

The optimized structure 3(2)-12-2 presented on Fig. 2, was trained using the data set including $\pm 15\%$ distribution of IM parameters. The DFOC drive system with the RNN estimator was simulated in Matlab/Simulink using 7.5 kW IM model in phase coordinates. The chosen RNN estimator structure allows considerable decrease in the absolute identification error of the rotor flux vector in the DFOC system with distributed parameters (see Fig. 3) and, as the result, the reduction of the torque fluctuations (Fig. 4).



a)



b)

Fig. 3. DFOC with 15% resistance change and applying: a) CE; b) RNN estimator.

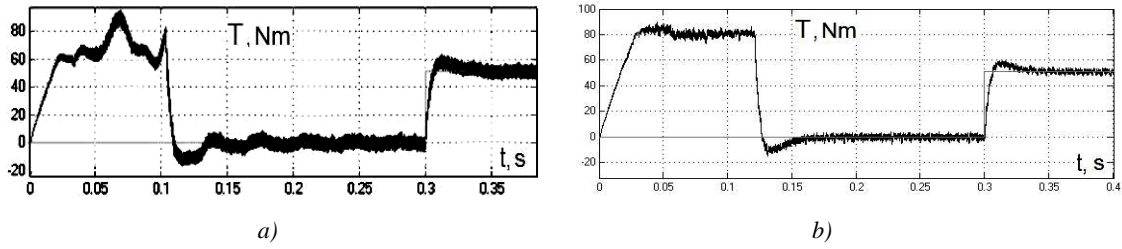

Fig. 4. Electromagnetic torque in DFOC drive with 15% resistance change and applying: a) CE; b) RNN estimator.

5. Experimental results

Proposed approaches were implemented on the physical model of the DFOC drive system. Therefore, the experimental setup shown on Fig. 5 was developed. It consists of 3-phase 0,55 kW IM with DC load generator (look App.1), 1,5 kW VSI (IPM11015), 1-phase rectifier with filter capacitance, two current sensors (LEM), pulse encoder for speed measurement, microcontroller with DSP (TMS320F2812 series) and a personal computer with programming software.

The software modules for the DFOC system implementation consist of two current PI-regulators, flux/speed PI-regulators with anti-windup, flux/speed estimators, units for transformation of coordinates, etc. The control system loops were adjusted for the optimal response. The RNN of the 3(2)-12-2 structure was off-line trained and than two software modules were added

to the DFOC control system. They are: the module for the approximation of the non-linear activation function and the module for RNN realization using matrix product.

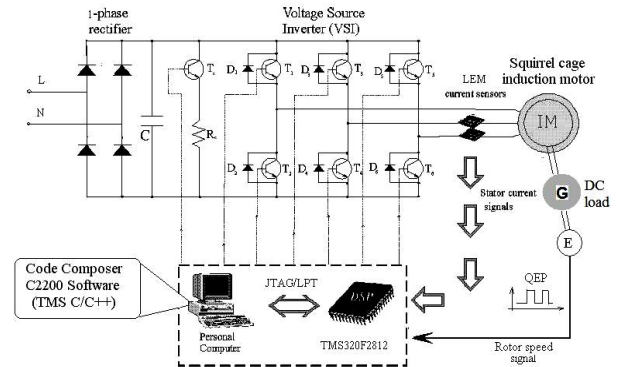

Fig. 5. The experimental setup for RNN implementation.

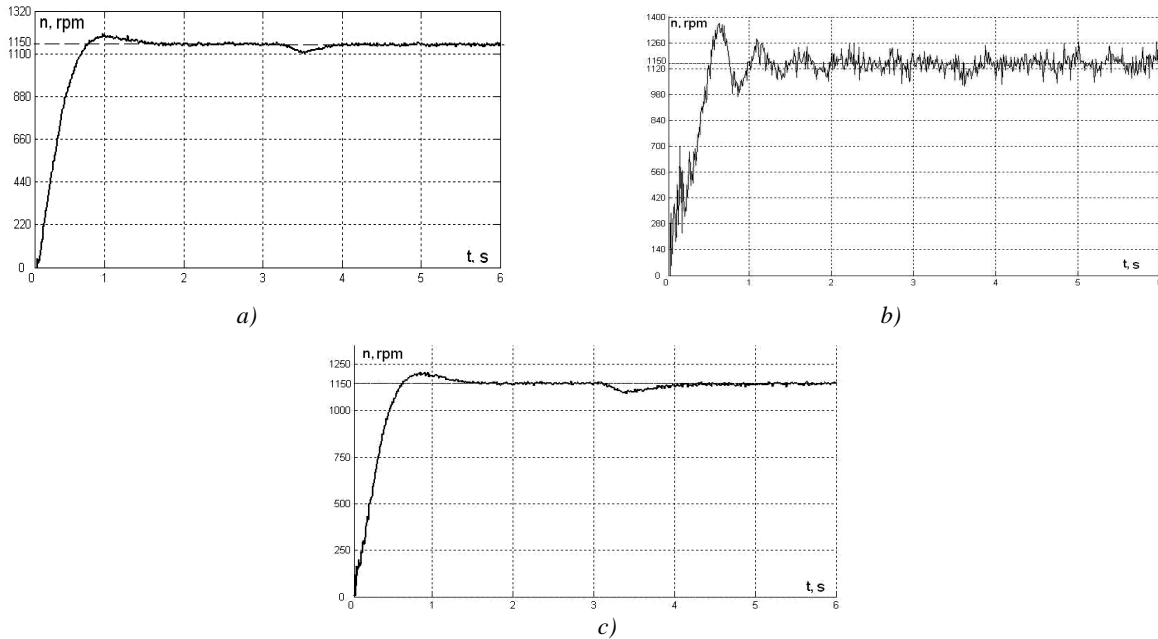

Fig. 6. Rotating speed signal in the cases of the experiment: a) case 1; b) case 2; c) case 3.

To confirm the results obtained with the mathematical model of the drive system, three experiments were carried out with the above-described setup:

- DFOC drive with cold motor and CE of the rotor flux vector.
- DFOC drive with warm motor and CE of the rotor flux vector.

- DFOC drive with warm motor and RNN estimator of the rotor flux vector.

The results were obtained during the start of the system and applying of the rated load after the 3-rd second. The speed signals present in control system are shown on Fig. 6.

A better speed signal characteristic in the DFOC system is achieved by neglecting the flux estimation error by the RNN estimator. Like the mathematical model of the DFOC drive, that error appears in warm motor with CE (with the change of the stator and rotor resistances).

Besides the improvement of DFOC drive characteristics with CE when the motor is warm or saturated, RNN based estimator shows the increase in IM drive resistance to non-accurate identification of parameters.

Taking into account the non-regulated rectifier, we propose using one phase DC modulated voltage for the stator resistance estimation, as it is shown in Fig. 7.

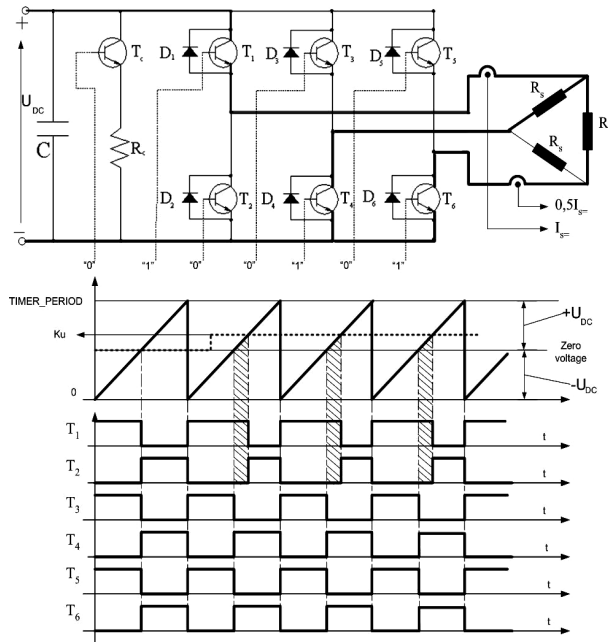

Fig.7. Modulation of 1-phase DC voltage with inverter.

For the delta-connected windings of the stator of the induction motor (Fig. 7) after N tests stator resistance could be calculated by the next formula [8]:

$$R_1 = \frac{1}{N} \sum_{i=1}^N \frac{1}{2} \left(2 \frac{U_{A=}^i - k_1 \cdot I_{A=}^i - V_0}{I_{A=}^i} + \frac{U_{A=}^i - k_1 \cdot 2 \cdot I_{B=}^i - V_0}{I_{B=}^i} \right) \quad (12)$$

The result of R_1 identification is shown in Fig. 8. In this figure, a dashed line shows the stator resistance value identified with conventional no-load and short circuit tests at 50Hz.

It was also admitted that after more than 3 hours of motor work with full (rated) load, the stator resistance considerably increased to the value of 18.23 Ω .

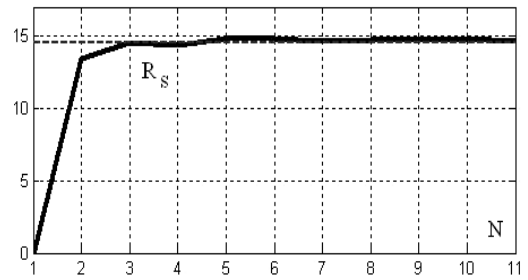

Fig. 8. Stator resistance identification at temperature $t = 25^\circ\text{C}$

Then the pre-described algorithm (Chapter 3) has been applied for the identification of parameters. Taking into account the temperature influence on motor parameters, two tests were done: one at temperature $t = 25^\circ\text{C}$ (Fig. 9, a) and another one after 3 hours of work with rated load (Fig. 9, b). As it is shown on Fig. 9, this method gives quite good results with satisfactory errors.

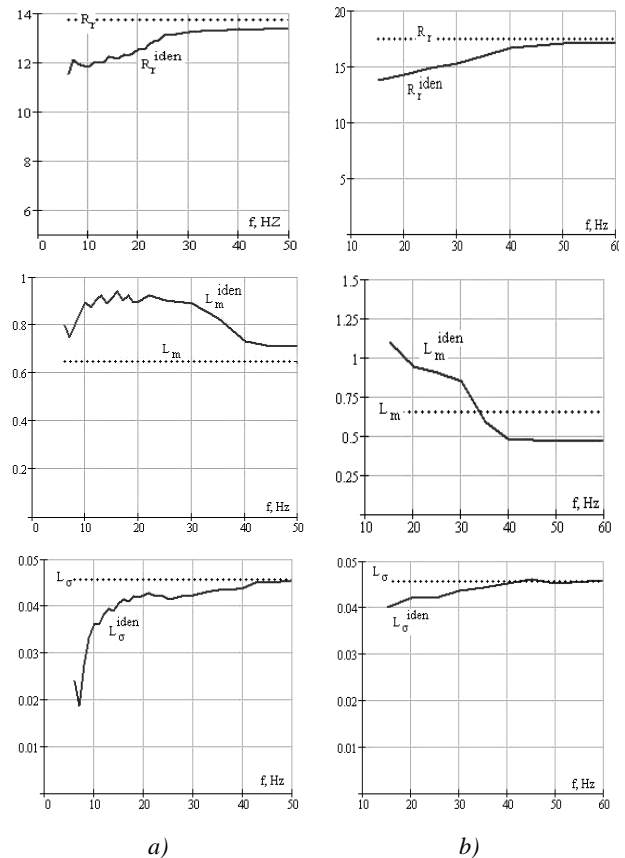

Fig. 9. Parameters identified with proposed method for various lower motor frequencies: a) at temperature 25°C ; b) after 3 hours of rated load work (warm motor).

As Fig. 9 shows, the method correctly identifies the increase in motor resistances as a result of the rise of temperature. But there is also a certain false shift in the estimated main inductance value (influence of the ignored iron losses). The leakage inductance

identification can be conducted quite successfully regardless of temperature. The analysis of graphs in Fig. 9 shows that the highest accuracy of the identified parameters could be achieved by choosing test frequencies close to the nominal frequency. For the 50 Hz motor, it could be the range from approximately 30 to 50 Hz.

6. Conclusions

The approach based on L_2 -sensitivity theory offers the possibility for classifying different FOC drives according to their sensitivity to the identification of accuracy of common parametric and state variables.

As it is shown, the pre-described method for the identification of the parameters with some proposed improvements provides good results and can be realized with relatively low implementation costs. In addition, with the use of IQ mathematics with 24 bits for the fixed point DSP, it took about 0.1 second for one frequency test.

The practical implementations of the proposed method into development of the industrial drives makes it possible to repeat the identification procedure during the operation in order to update the parameter values, especially for the temperature-dependent parameters. In the most cases it can be easily done using short pauses between the working cycles, or short no-working periods. That allows a precise setting of the parameters of the mathematical model used in a controller, which in turn will improve the characteristics of the whole FOC drive system.

The estimator with proposed RNN structure trained with modified algorithm provides high identification accuracy of flux linkage, good drive performance in all operating points, low drive system sensitivity to the parameter deviations, low noise level in the control system. These characteristics allow the increase of robustness of the whole drive.

Appendix 1

IM Nameplate Data

Con- nection	P_n , kW	U_n , V	f , Hz	I_n , A	$\text{Cos}\phi_n$	n, rpm
Δ / Y	0,55	230 / 400	50	2,8 / 1,6	0.72	1400

DC Generator

Excitation	P_n , kW	U_n , V	I_n , A	Performan- ce index, %	n, rpm
Separate	1,1	220	6.81	74	1500

References

[1] B. Bose, *Power electronics and AC drives*. Englewood Cliffs, New Jersey, USA: Prentice-Hall, 1986.
 [2] P. Vas, *Vector control of AC-machines*. Oxford University Press, 1990.

[3] S. Peresada, A. Tilli, and A. Tonielli, "Theoretical and experimental comparison of indirect field-oriented controllers for induction motors", *IEEE Trans. on Power Electronics*, vol. 18, no. 1, pp. 151–160, 2003.
 [4] D. Casadei, F. Profumo, G. Serra, and A. Tani, "FOC and DTC: Two Viable Schemes for Induction Motors Torque Control", *IEEE Trans. on Power Electronics*, vol. 17, no. 5, pp. 779–785, 2002.
 [5] B. Robyns, P. Sente, H. Buyse, and F. Labrique, "Influence of digital current control strategy on the sensitivity to electrical parameter uncertainties of induction motor indirect field-oriented control", *IEEE Trans. on Power Electronics*, vol. 14, no. 4, pp. 690–700, 1999.
 [6] W. Yan and J. Moore, "On L_2 -Sensitivity minimization of linear state-space systems", *IEEE Trans. Circuits Syst. I*, vol. 39, p. 641–648, 1992.
 [7] I. Smetana, A. Losynsky, M. Klytta, F. Garbrecht, "Method for parameters identification of an asynchronous machine", *Tekhnichna elektrodynamika. Proc. Conf. Power electronics and energy effectiveness, Part-3*, pp. 68–71, 2003. (Ukrainian)
 [8] I. Smetana, A. Losynsky, M. Klytta, and F. Garbrecht, "Identification of induction motor parameters at standstill using svpwm inverter and DSP-TMS320", *Tekhnichna elektrodynamika. Special issue on Proc. Conf. Power electronics and energy effectiveness*, 2005. (Ukrainian)
 [9] I. Smetana and A. Lozynsky, "Application of the ANN for the identification accuracy increasing of the flux linkage in the vector control systems", *Elektromachynobuduvannia ta elektroobladnannia*, vol. 63, pp. 7–16, Kyiv, Ukraine: Tekhnika, 2004. (Ukrainian)
 [10] I. Smetana, A. Lozynsky, "Flux Identification in Field-Oriented Controlled Drive by Recurrent Neural Networks", in *Proc. ISC PELINCEC'2005*, Warsaw, Poland, 2005.
 [11] I. Smetana, A. Lozynsky, "The analysis of sensitivity of the vector control electric drive systems with cage rotor induction motor to parametric disturbances", *Elektroenerhetychni ta elektromekhanichni systemy*, no. 479, pp. 172–179, Lviv, Ukraine: Lviv Polytechnic National University, 2003. (Ukrainian)
 [12] M. Veles-Reyes, G. Verghese, "Robust decomposed algorithms for speed and parameter estimation in induction machines", in *Proc. IMACS-TCI*, pp. 95–100, 1993.
 [13] B. Raison, J. Arza, G. Rostaing, and J. Rognon, "Comparison of two extended observers for the resistance estimation of an induction machine", in *Proc. Industry Application Conf.*, vol. 2, pp. 1330–1335, 2000. DOI: 10.1109/IAS.2000.882056

- [14] J. Seok, S. Moon, and S. Sul, "Induction machine parameter identification using PWM inverter at standstill", *IEEE Trans. on Energy Conversion*, vol. 12, no. 2, pp. 127–134, 1997.
- [15] Toliyat H.A., Levi E., Raina M., "A Review of RFO Induction Motor Parameter Estimation Techniques", *IEEE Trans. on Energy Conversion*, vol. 18, no. 2, pp. 271–283, 2003.
- [16] O. Pinto, B. Bose, E. Borges da Silva, "A Stator-Flux-Oriented Vector-Controlled Induction Motor Drive With Space-Vector PWM and Flux-Vector Synthesis by Neural Networks", *IEEE Trans. on Industry Applications*, vol. 37, no. 5, pp. 1308–1319, 2001.
- [17] T. Orłowska-Kowalska, "Artificial neural networks in electrical drives control – a survey", *Archives of electrical engineering*, vol. XLVII, no. 184–2, Warsaw, Poland, 1998.
- [18] W. Lei, Z. Guo-Xing, and W. Qi-di, "Hopfield Neural Network Based Identification and Control of Induction Motor Drive System – Part I: Identification", in *Proc. 14th World Congress of IFAC*, pp. 265–296, 1999.
- [19] V. Terekhov, D. Yefimov, and I. Tyukin, *The simplest control systems*. Moscow, Russia: Radiotekhnika, 2002. (Russian)

МЕТОДИ ЗМЕНШЕННЯ ПАРАМЕТРИЧНОЇ ЧУТЛИВОСТІ ЕЛЕКТРОПРИВОДУ ВЕКТОРНИМ КЕРУВАННЯМ

Ігор Сметана, Андрій Лозинський,
Валерій Місюренко

Розглянуто проблему параметричної чутливості електроприводу з векторним керуванням. Запропоновано аналітичний метод дослідження чутливості систем з такими електроприводами. На підставі використання результатів математичного моделювання, отриманих із застосуванням вказаного методу, та запропоновано рекомендації щодо зменшення параметричної чутливості. Запропоновано ефективний метод ідентифікації параметрів асинхронного двигуна. Визначено оптимальну структуру штучної нейронної мережі для ідентифікації магнетного потоку при дії параметричних збурень в системах векторного керування електроприводом.



Igor Smetana – PhD (2005), thesis theme "Increasing of robustness of induction motor control systems". He graduated from Lviv Polytechnic National University, Ukraine, in 2002 with major in Electric machines and apparatus. He worked at Schneider Electric Ukraine (2006-2013). Since 2013 - ES-SYSTEM Ukraine, CM/ Director of representation office. Author of 15 scientific articles.



Andriy Lozynsky – D.Sc. of Engineering (2004), Professor (2006). He graduated in 1993 from Lviv Polytechnic Institute, Ukraine, with major in "Electric drive and automation of industrial enterprise and technological complexes". After completion of post-graduate studies and defense of PhD thesis (1996) he worked at the Department of electrical machinery and apparatus at Lviv Polytechnic National University. Since May 2004 - Deputy Pro-Rector for Research at Lviv Polytechnic National University. Since December 2014 – Director of Institute of Power engineering and Control Systems. Expert of several international projects. The Grant Holder of Ukrainian Cabinet of Ministers in 2001–2002. Leader of the Grant of President of Ukraine for support of scientific researches of young scientists in 2006. He took part in researches projected financed by Ministry of Education and Science of Ukraine in 1997 – 2014. Main direction of research is development of intellectual control systems for electrical engineering systems. Author and coauthor of 3 monographs, over 140 scientific articles, 5 tutorials, 8 patents of Ukraine and 2 patents of Russian Federation.



Valeriy Misyurenko – PhD, Associate Professor of Department of Electric Drive and Computerized Electromechanical Systems, Lviv Polytechnic National University, Ukraine. Research interests: theoretical and applied problems of automation of industrial mechanisms using frequency-controlled electric drives. Co-author of three textbooks and over 40 articles.