

POLISHING TOOL WITH CYCLOIDAL MOVEMENTS ROTATION FOR THE MANUFACTURE OF FLAT SURFACES WORKING ELEMENT $\text{Li}_2\text{B}_4\text{O}_7$

@ Prots L. A., Lavrinenko V. I., 2016

This work relates to the technology of mechanical treatment of flat surfaces of metal parts and can be used in various industries in the manufacture of optical components, including working elements of quantum devices with tetraborate lithium. For the research on the production of flat surfaces has been developed polishing tool with cycloidal motion of rotation which polishes the flat surface of high planarity and increases the productivity of mechanical treatment processes.

Key words: mechanical treatment, lithium tetraborate, polishing tool, cycloidal motion.

Представлена робота відноситься до технології механічної обробки плоских поверхонь неметалевих деталей і може бути використана у різноманітних галузях промисловості при виготовленні оптичних деталей, зокрема, робочих елементів квантових приладів з тетраборату літію. Для проведення досліджень по виготовленню плоских поверхонь було розроблено полірувальний інструмент з циклоїдальними рухами обертання який полірує плоскі поверхні високої площинності та збільшує продуктивність праці процесів механічної обробки.

Ключеві слова: механічна обробка, тетраборат літію, полірувальний інструмент, циклоїдальні рухи.

Significant growth of the role of non-metallic materials for modern electronics functional causes continuous expansion work on the search for new materials with desired properties. Research on tissue equivalent materials with thermo-luminescent properties at the present stage are carried out in Japan, Korea, China, India, Vietnam, Switzerland, Estonia, Croatia, Serbia, Turkey and Ukraine. According to the latest the world tendencies, recent developments in the technology of obtaining thermoluminofors concentrated mainly on finding the most effective combinations of dopants for mono- and polycrystalline materials based on individual compounds, their preparation and production of functional materials with thermo-luminescent work items to thermoluminescence dosimetry.

Among the large number of materials with similar properties, synthesized and tested in recent times, it is known compositions based on mono and polycrystalline lithium tetraborate $\text{Li}_2\text{B}_4\text{O}_7$. This material with a large piezoelectric constant and a promising for use in laser oscillators, thermostable devices, strain gauges in the form of a compressed ceramic alloy thermoluminescent dosimetry and neutron γ - radiation devices in surface acoustic waves, etc. [1]. Obviously, the most important area of application is doped polycrystalline $\text{Li}_2\text{B}_4\text{O}_7$ dosimetry of ionizing radiation. Known tissue equivalent thermo-luminescent dosimeters X-ray, gamma -, neutron and mixed gamma-neutron radiation storage type based on $\text{Li}_2\text{B}_4\text{O}_7$ action is based on the effect of luminescence thermostimulating manufacturing firms Panasonic (Japan), Bicron (USA), Rados (Finland), which are already widely Spread. It is clear that a wide range of possibilities of use of mono and polycrystalline lithium tetraborate is impossible without the development and application of a particular technological cycle of mechanical treatment in the making of his work features and functional quantum

electronics [2].

Separately, it is noted that production of experimental samples with mono and polycrystalline lithium tetraborate is the primary stage of introducing machining technologies in optical instrumentation. In the manufacture of various optical devices put some, sometimes quite strict conditions on the quality of working surfaces, especially when it comes to equipment, the creation of which is based on the use of optical contacts (OC). Note that the optical contact is called a contact connection between two solid surfaces, highly polished and pulled together at a distance, a much smaller wavelength of light (nm order). The geometrical thickness of OC depends on the quality of processing the substrates and is not constant over the entire surface of the sample in contact [3]. On the strength of the optical contact fittings affected by many factors such as the purity of its surface roughness, flatness (N) connecting surfaces, unlike thermal linear expansion coefficients of the contacting materials, and so on. It should be emphasized that the flatness of the mating surfaces have the most significant impact on the quality OK. Getting polished surfaces with the corresponding high values of N, and the flatness of its local error ΔN is problematic on surface grinding machines, working on the principle of translational motion back processing of samples and the rotational movement of the tool. With such processing nearly impossible to achieve high flatness machined surfaces along its entire length. We should also focus on the problems of lack of machinery and equipment which, without the use of specific innovative tools and mechanical treatment could work with a variety of mono and polycrystalline materials whose hardness is substantially different from the metal samples. Moreover, most operations promising new machining metallic materials requires considerable labor personal opticians elements quantum devices, which considerably increases the complexity which in turn reduces the productivity. Thus, the creation of new methods of mechanical treatment with innovative tools that could provide high levels of flatness N and ΔN mono and polycrystalline surfaces of lithium tetraborate and increase productivity at the same time is obviously an important issue.

The aim of this work was precisely with use of a polishing tool rotational cycloidal movements for producing planar surfaces of working elements with a flatness $\text{Li}_2\text{B}_4\text{O}_7$ corresponding to $N = 4$, $\Delta N = 1$ to increase the performance of these processes, polishing materials during the execution cycle of mechanical treatment.

Was manufactured and used a special device with an innovative tool for polishing processes of mechanical treatment of flat surfaces to achieve this goal. [4] As test samples a series of 12 elements working mono and polycrystalline lithium tetraborate dimensions 17x19x26 mm were utilized. Studies were conducted on the flatness interferometer IT 100 A, with a wavelength of 0,6328 micron in.

Application of the device developed by us was to cater to the needs of flatness $N = 4$, $\Delta N = 1$ planar treatment surfaces of working elements and increase the productivity of machining. In carrying out the proposed method has been refined, manufactured and tested the specific form of the instrument and scheme of the technological cycle of polishing machining plane.

In Fig. 1 schematically illustrates the working of the device, which was used in this work at polishing of flat samples of lithium tetraborate.

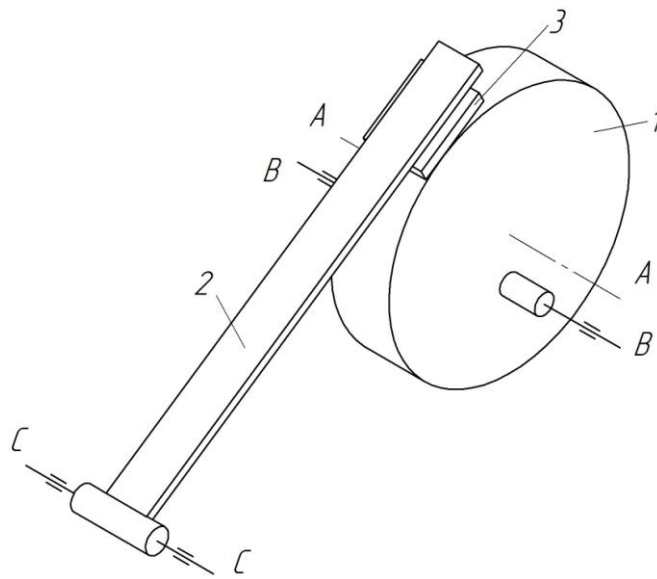

Fig.1 The general scheme of the working part of the instrument.

A general scheme of the special device in Fig 1, comprising a polishing tool 1 constructed in the form of a cylinder whose rotation axis B - B is positioned horizontally and parallel to its axis of symmetry A - A, in order to allow cycloidal motions. To establish the processed element 3 with lithium tetraborate applied holder 2, which with one end fixed is hingedly C - C and is mounted for rotation about an axis parallel to the working element the rotation axis B - B, which in turn is located in a horizontal plane parallel to the axis its symmetry A - A. Consequently polishing tool rotation axis and pivotally mounted holder pivot axis lie parallel to the symmetry axis of the polishing tool.

The principal difference between the applied polishing tool is that it is designed in such a way that his head movement was cycloidal - rotating, and the working surface - end [5].

By cycloidal motions when the tool rotation is a constant change in its contact area with the working element $\text{Li}_2\text{B}_4\text{O}_7$ treated surfaces. Thus, there is contact over the entire surface treated with the lifting element with allowance flat profile profile during the production cycle processes abrasive mechanical treatment with mono- and polycrystalline lithium tetraborate.

For a more detailed explanation of the technological possibilities provided by the circuit implementation of the technological processes of abrasion mechanical treatment of the samples with $\text{Li}_2\text{B}_4\text{O}_7$ in Fig. 2 shows the extreme positions of the processed work item on a special stage cycloidal rotation of the working tool.

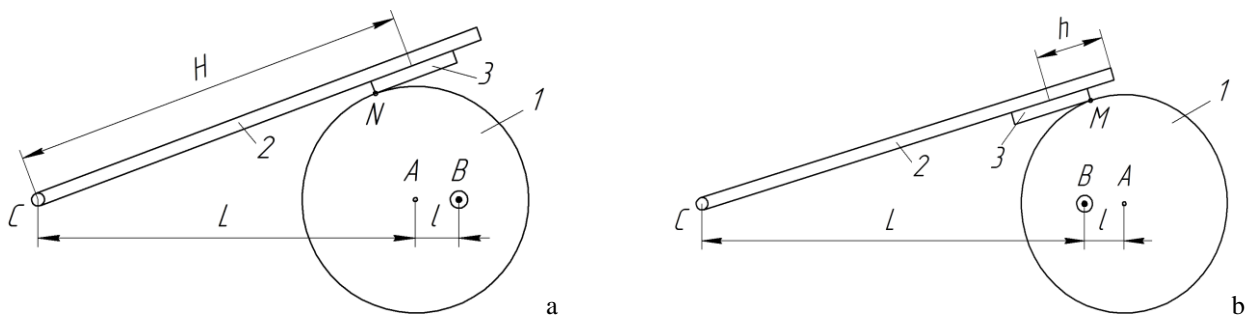

Fig.2. Scheme position a workpiece at various stages of rotation cycloidal special working tools:

- a. that the proximal surface of the workpiece to position the pivot axis of the holder;
- b. is the far surface of the workpiece to position the pivot axis of the holder.

Fig. 2 shows that the tool 1 has a cylindrical shape, where the distance between the tool axis of symmetry A - A and its rotation axis B - B is equal to l (see figure 1). The holder 2 for an optical part 3 with lithium tetraborate, which is processed, is pivoted on the axis C - C, and the optical part 3 is fixed to the free end of the holder 2.

Point N, to the position shown in Fig. 2.a, it corresponds closest to the holder the pivot axis (point C) the position of the line of contact surface of the tool 1 and the surface of the processed optical part 3 $\text{Li}_2\text{B}_4\text{O}_7$. Note that points A, B and C are located on the same straight line.

Considering that $BC = L$, $MN = h$, $AB = l$, $AN = R$ (R – radius of the tool, and $CN = H - \frac{h}{2}$ of a right triangle ACN receive:

$$(L-l)^2 = \left(H - \frac{h}{2}\right)^2 + R^2 \quad (1)$$

Point M, fig.2.b corresponds exactly farthest position from the point C, that is, the holder rotation axis 2 of the contact line between the surface of the optical part 3, and the treated surface of the instrument 1. For this position:

$$(L-l)^2 = \left(H + \frac{h}{2}\right)^2 + R^2 \quad (2)$$

Considering the equation (2) from equation (1), we obtain:

$$L^2 - 2Ll + l^2 - L^2 - 2Ll - l^2 = H^2 - Hh + \frac{h^2}{4} + R^2 - H^2 - Hh - \frac{h^2}{4} - R^2, \\ 2Ll = Hh. \quad (3)$$

It should be noted that the course of the line of contact details and the working surface of the polishing tool should be either equal to or greater than h to ensure cycloidal motion of the tool during mechanical treatment of the surface treated optical parts of mono- and polycrystalline lithium tetraborate. Despite this for the distance l , which is the following requirement must be carried out between the symmetry axis and the axis of rotation of the processed work item:

$$l \geq \frac{Hh}{2L}. \quad (4)$$

For mechanical treatment of the proposed scheme to the free end of the holder 2, (div.ris.1 and Fig. 2) attached workpiece 3 with lithium tetraborate, so that the treated surface facing the working surface of the polishing tool 1.

The polishing tool is formed into a cylindrical shape. Working surface of the tool is its peripheral portion, on which a foundation of soft fabric and a layer of abrasive polishing paste ACM 2/1. A holder attached to the treated sample $\text{Li}_2\text{B}_4\text{O}_7$ coated abrasive material is slowly lowered to the working surface of the tool and include a rotational movement of the tool. Thus there is a cycloidal rotation of the tool, which is carried out by shifting the tool axis of rotation with the axis of its symmetry. Thus there is the removal of a layer of material from all over the treated surface by $\text{Li}_2\text{B}_4\text{O}_7$ back and gradually moving parts on the line of contact with the working surface of the tool. the tool rotation speed is 10 rev / min. Due to the fact that the distance between edge positions of contact line is greater than the length of the surface treated and constituted in this case 44 mm, next the workpiece is fixed and the plate as well, with the flat surfaces of the same material to be treated with lithium tetraborate 17 mm, so that surface of the workpiece surface which was treated, were in the same plane. During the polishing process on the proposed instrument through the use of cycloid-rotational movement of the polishing tool were obtained polished surface $\text{Li}_2\text{B}_4\text{O}_7$ sizes 17x19 mm and 17x26 mm for which research results of the flatness of the IT 100 A meets $N = 4 - 4,5$; $\Delta N = 0,5 - 1$.

It should also be noted that by using the proposed method has been the use of time snizino cost of manufacturing an optical part of one surface by 75%. Such reduction in working time is due to the fact that after the mounting on the treated sample holder part optics quantum devices during polishing elements is reduced to observation. This application of the working time costs for the production of a surface reduces the complexity of manufacturing the optical parts of $\text{Li}_2\text{B}_4\text{O}_7$ than increasing production. And this change of indicators of development and complexity of about 4 times increase the productivity of technological operations polishing of flat surfaces with $\text{Li}_2\text{B}_4\text{O}_7$ for details functional electronics.

As a result of research carried out in the framework of the cycle of processes of polishing flat polished surfaces $\text{Li}_2\text{B}_4\text{O}_7$, found that the use of cycloid-rotating main tool movements during polishing of flat ground surfaces with $\text{Li}_2\text{B}_4\text{O}_7$ provides uniform removal of material across the surface that is processed and the flatness of the processed samples just falls within the necessary requirements, namely $N = 4$, $\Delta N = 1$. It was also found a significant increase in productivity by reducing the complexity of the processes of polishing process cycle mechanical treatment.

Literature:

1. Holovej V.M. *Krystalichnij i sklopodybnij $\text{Li}_2\text{B}_4\text{O}_7$: vpliv fyzyko-chymychnuh umov oderzhannya na vlastuvosty vporyadkovanuh ta defektnuh struktur na joho osnovy: avtoref. dus. dokt. chym. nauk /V.M. Holovej – Kyiv, 2009. – 31 s.* 2. Poperenko L.V. *Texnologya obrobku optuchnux poverxon / L.V. Poperenko, Yu.D. Fylatov – K.: Vudavnychno-polygrafychnyj centr “Kyivskij universytet” 2004. – 166 s.* 3. Vynogradov A.N. *Problemu optycheskogo kontakta pry soedynenyu elementov gelyj-neonovogo lazera / A.N. Vynogradov, N.P. Zapotulko, A.A. Katkov, E.V. Matveev // Optucheskyj zhurnal. – 2014. – T. 81, Vup. 4. – S. 61–67.* 4. Prots L.A. *Doslydzhennya procesyv vugotovlennya optuchnux eiementyv akustooptuchtuh monocystalyv / L.A. Prots // Problemu mashynostroenya. . – 2013. – Tom 16, № 6. – S. 66–70.* 5. Prots L.A. *Zastosuvannya cykloidalnih ruhiv obertannya instrymentu dlya mehanycnoi odrobku ploskuh poverhon kompozutyv na osnovi borosylycatnogo skla z napyvprovodnykovumu nanokrystalamu CdSe1-xTex / L.A. Prots // Naukovi notatki. Lutsk. – 2015. – Vup. № 49. – S. 131–135.*