

INVESTIGATION OF THE DYNAMICS OF VIBRATORY SEPARATOR WITH UNBALANCED DRIVE

© V.G. Topilnytskyy, Z.A. Stotsko, J. M. Kysyj, D.P.Rebot

Annotation: *In the article, using the self-reactance mathematical model of motion of oscillation separator with an occasion and spring pendant, on the basis of the built dependences (amplitudes of vibratory container of oscillation separator are from his kinematics and structural parameters), recommendations are worked out in relation to the choice of parameters of oscillation separator, which will provide most intensity of separation processes in him.*

Statement of the problem. The application of separators in engineering, mining, construction, food and other industries is extremely widespread and growing steadily. Topical task is to develop advanced, relatively simple structures vibrating separators and their analytical study. The last enables at the design stage of vibratory separators to optimize their designs by constructing mathematical models and studying their movements on the basis of the model dynamics separators. Mathematical models make it possible to comprehensively determine the effect of design parameters and operating modes of vibration characteristics of the separator and loose environment that is separated on the intensity factors of the process of separation of products and, therefore, at the design stage to optimize the design of the separator due to the maximum intensity of the separation of granular media in it, and reduce the time and reduce the cost of development projects by reducing the amount of experimental research.

Analysis of the known research and publications. The review of designs of separators indicates their extreme diversity as the principle of action and by substances that are separated, the quality of the process of separation. Analysis of the literature indicates on the opportunities vibration separation process granular materials into fractions. Topical is a new approach to the calculation and design of vibratory separators using theoretical and practical foundations of the research and design of vibration equipment [1, 2, 3]. They lie in the study of dynamic processes in vibratory separator based on mathematical modeling.

Statement of the problem. In this paper, using obtained unified parameterized model of vibratory separator with unbalanced drive and spring suspension [4] studied its dynamics. This model can be used (by changing its parameters or vanishing) for a wide range of designs vibrating of separators like working with three containers and of separators for two or one working containers with a variety of their relation to each other and the frame or suspension separator. A model, of a vibrating separator includes all the dynamic events that occur in it, allows to study the effect on the vibration amplitude of vibration separator container, its basic parameters (parameters that can be changed during operation of the separator) get image depending on the amplitude of the separator container on its parameters and the trajectory motion of arbitrary points in the plane of the containers fluctuations. These dependencies can be used to select the desired mode of operation of the separator. Based on the constructed dependence (amplitude of vibration separator container on its kinematic and structural parameters in various combinations with each other) and by universal optimization criterion , we can develop recommendations on the choice of parameters of vibrating separator with three working containers, spring suspension and unbalanced drive that will provide greatest intensity separation processes in it.

The main material. The principal scheme of the investigated vibratory separator is shown in Fig. 1. Figure the following notation: 1 - working container of vibratory separator, 2 - unbalance 3 - belt clutch 4 - frame of vibratory separator, 5 - set of screens for separation.

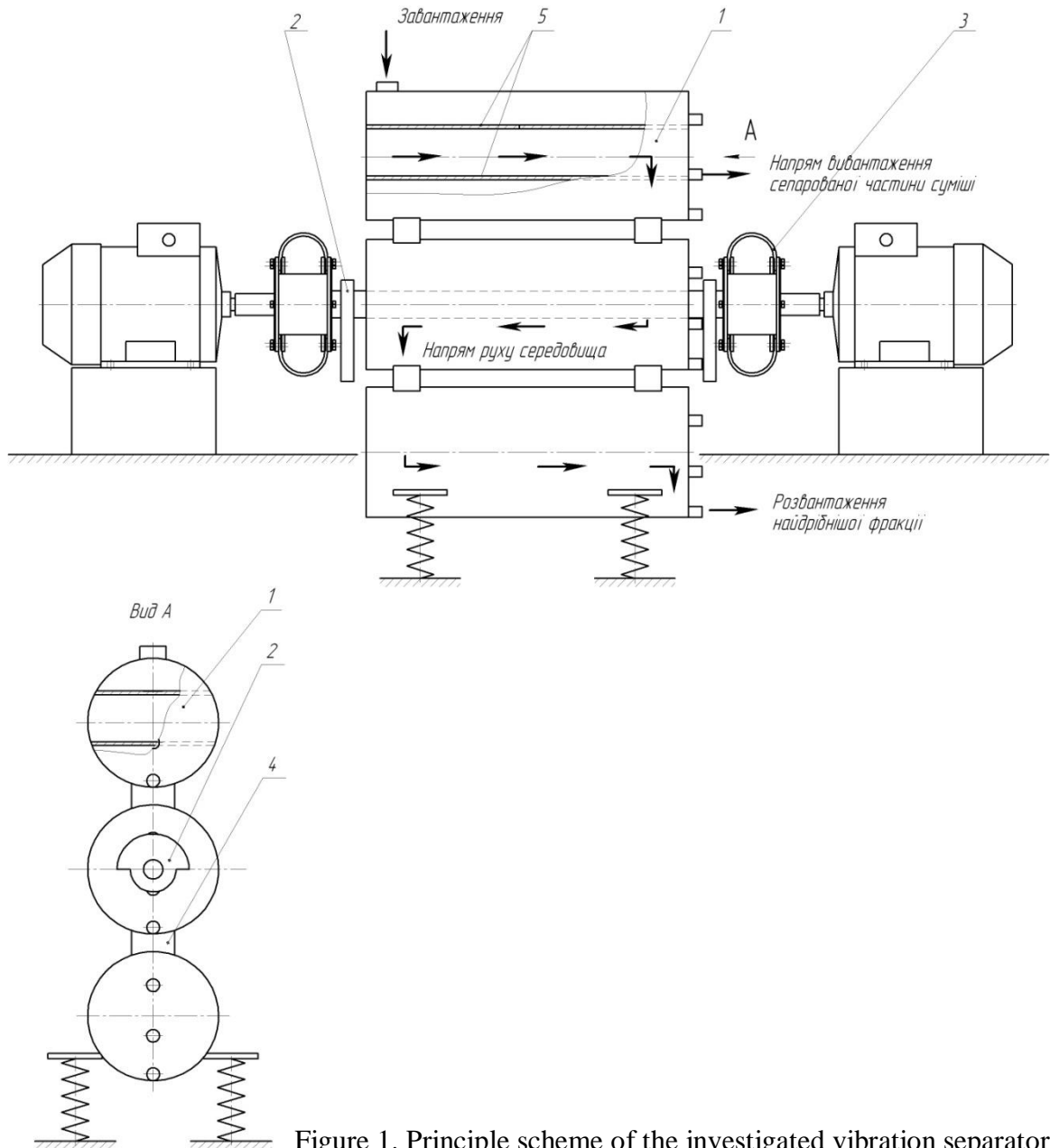

Figure 1. Principle scheme of the investigated vibration separator.

Vibrating separator consists of three working containers 1, in which there are 5 separation screens with different size cells. Largest cell is on the top sieve of the top container, the lowest - in the lower sieve bottom of the container. In working containers can be set from 0 to 6 screens (2 screens in each container). So now separator can hold the maximum separation of the mixture into 9 fractions (three fractions in each container - two sieves accumulate on the third - on the bottom of the container). Containers connected by branch pipes which also established separation sieve. The mixture, which should be divided, loaded at the top of the container. Under the influence of unbalance 2, which are driven by asynchronous electric motors through belt clutch 3 working containers begin to vibrate making flat movement. Work the mixture is thrown and moved (by varying the amplitude of the left and right with different unbalance unbalanced masses) along the top of the container. The largest particles are fed to the upper and lower fall through to the lower sieve. It also remains a particle of a certain size, which does not pass through the cell corresponding sieve. The rest of the mingle falls to the bottom of the upper container and passed through a sieve connecting pipe, which also separates one faction gets on the top sieve of the second (middle of container), etc. The process of separating the middle and lower containers is the same as on the top. The resulting mingle is separated into 9 parts. After the separation process, the operator turns off the drive, open side vents for containers (each container of 3 - range of sieves and bottom) and activates the drive of separated mixture under vibration of vibrating separator is discharged to the outside -

each fraction separately by size in separate tray. So the investigational vibrating separator is working.

Design scheme of a generalized vibrating separator. Design model of vibratory separator (Fig. 2) is represented as a flat mechanical system having four degrees of freedom (three degrees have the containers and one - unbalance, which rotates around a horizontal axis in the same plane).

[4]

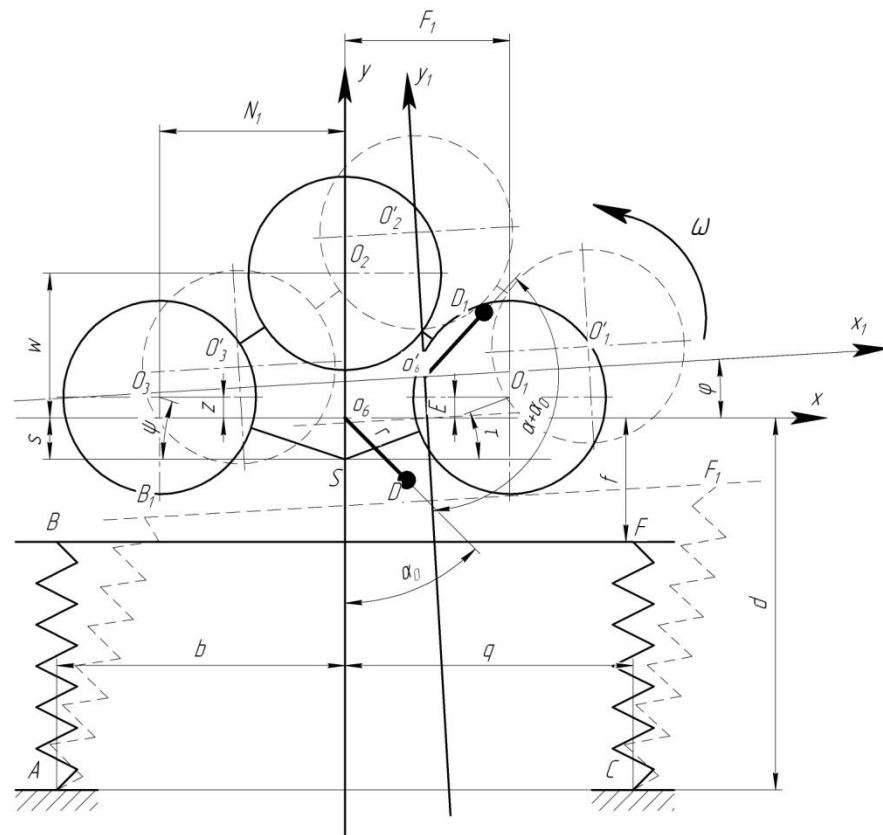

Fig. 2. Design model of a generalized vibrating separator with three containers of arbitrary location.

The scheme working containers with masses of M_{k1} , M_{k2} , M_{k3} , XO_6Y - fixed coordinate system; $X_1O_6Y_1$ - moving coordinate system associated with the center of rotation unbalance and the vertical axis of symmetry of containers moving along with them, and its origin - O_6 point 'coincides with the center of rotation unbalance; φ - angle of the container relative to the initial position during its motion (the angle of rotation of the movable relative to the fixed coordinate system). At the initial time centers of movable and immovable coordinate systems coincide, the geometric center of the container is at the point O_6 , and its center of mass - point S lies on the axis Y . Let O_1 , O_2 , O_3 - geometric centers of containers of vibrating separator; $O_6D = r$ - radius of rotation unbalance (the value of unbalance eccentricity). We assume that the mass M_d - unbalance mass is concentrated at one point; ω - angular velocity of unbalance (take it a constant for a particular mode of treatment); α_0 and $\alpha + \alpha_0$ - initial phase unbalance position; $\alpha = \omega t$ - angle of the unbalance at any moment in time relative to the initial position; C - total stiffness of elastic elements; C_1 and C_2 - stiffness respectively right and left suspension; L_{np} - undeformed length of the suspension (springs); AB_1 and CF_1 - length of the spring at any point in time the movement of the container; AB and CF - length of the spring at the initial time; b and q - distance from the poles of the left and right suspension to the axis O_6Y - fixed coordinate system.

A mathematical model of motion (1) of investigated the vibration separator constructed through the use of asymptotic methods of nonlinear mechanics [5] and the II kind Lagrange equation. It is a unified, all parameters of vibrating separator include a symbolic form, and thus, they can vary depending on which mode of vibration separator should be investigated. The resulting system of equations describing the motion of a vibrating separator for an arbitrary amount of time it works.

$$\begin{aligned}
x_{0_6}(t) = & x_0 \sin \left(\sqrt{\frac{C}{M}} t + \alpha_x \right) + \\
& + \int_0^t \left[\begin{aligned} & k^2 (L_1 \sin kt + L_2 \cos kt) (M_{\text{Д}} r \cos(\omega t + L_1 \sin kt + L_2 \cos kt + \alpha_0) + \\ & + M_{K_1} [(F_1 t g \tau + S) \cos(L_1 \sin kt + L_2 \cos kt) - F_1 \sin(L_1 \sin kt + L_2 \cos kt)] - \\ & - M_{K_2} W \cos(L_1 \sin kt + L_2 \cos kt) + \\ & + M_{K_3} [N_1 \sin(L_1 \sin kt + L_2 \cos kt) + (N_1 t g \psi + S) \cos(L_1 \sin kt + L_2 \cos kt)] - \\ & - (L_1 k \cos kt - L_2 k \sin kt)^2 \times \\ & \times \left[\begin{aligned} & M_{K_1} (F_1 \cos(L_1 \sin kt + L_2 \cos kt) + (F_1 t g \tau + S) \sin(L_1 \sin kt + L_2 \cos kt) + \\ & + M_{K_2} W \sin(L_1 \sin kt + L_2 \cos kt) + M_{K_3} (N_1 \cos(L_1 \sin kt + L_2 \cos kt) - \\ & - (N_1 t g \psi + S) \sin(L_1 \sin kt + L_2 \cos kt)) + (P t g \gamma + S) \sin(L_1 \sin kt + L_2 \cos kt) \end{aligned} \right] + \\ & + M_{\text{Д}} r (\omega + L_1 k \cos kt - L_2 k \sin kt) (-C_2 q + C_1 b) - \sin(L_1 \sin kt + L_2 \cos kt) \times \\ & \times (C_1 d - C_2 f) + C_2 q - C_1 b \end{aligned} \right] du,
\end{aligned}
\tag{1}$$

$$\begin{aligned}
y_{0_6}(t) = & y_0 \sin \left(\sqrt{\frac{C}{M}} t + \alpha_y \right) + \\
& + \int_0^t \left[\begin{aligned} & k^2 (L_1 \sin kt + L_2 \cos kt) (M_{\text{Д}} (r \sin(\omega t + L_1 \sin kt + L_2 \cos kt + \alpha_0) + \\ & + M_{K_1} (F_1 \cos(L_1 \sin kt + L_2 \cos kt) + \\ & + (F_1 t g \tau + S) \sin(L_1 \sin kt + L_2 \cos kt) - M_{K_2} W \sin(L_1 \sin kt + L_2 \cos kt) + \\ & + M_{K_3} ((N_1 t g \psi + S) \sin(L_1 \sin kt + L_2 \cos kt) - N_1 \cos(L_1 \sin kt + L_2 \cos kt)) - \\ & - K \cos(L_1 \sin kt + L_2 \cos kt))) - (L_1 k \cos kt - L_2 k \sin kt)^2 \times \\ & \times (M_{K_1} ((F_1 t g \tau + S) \cos(L_1 \sin kt + L_2 \cos kt) - F_1 \sin(L_1 \sin kt + L_2 \cos kt)) - \\ & - M_{K_2} W \cos(L_1 \sin kt + L_2 \cos kt) + M_{K_3} (N_1 \sin(L_1 \sin kt + L_2 \cos kt) + \\ & + (N_1 t g \psi + S) \cos(L_1 \sin kt + L_2 \cos kt)) - P \sin(L_1 \sin kt + L_2 \cos kt)) - \\ & - M_{\text{Д}} r (\omega + L_1 k \cos kt - L_2 k \sin kt)^2 \cos(\omega t + L_1 \sin kt + \\ & + L_2 \cos kt + \alpha_0) + \cos(L_1 \sin kt + L_2 \cos kt) (C_1 d + C_2 f) + \sin(L_1 \sin kt + L_2 \cos kt) (C_1 b - C_2 q) - \\ & - d(C_1 + C_2) + (M_{K_1} + M_{K_2} + M_{K_3} + M_{K_4} + M_{\text{Д}}) g \end{aligned} \right] du,
\end{aligned}$$

$$\varphi(t) = L_1 \sin kt + L_2 \cos kt.$$

Using the mathematical model of motion of a vibrating separator and package of automated calculations MahtCad, was investigated the effect of geometric and kinematic parameters of a vibrating separator for vibration amplitude "geometric center" of the separator (as a base point for the description of its movement) generalized vibration separator with unbalanced drive and spring suspension in steady state operation (unbalanced vibratory separator with vibrozbudnykom works primarily in the area of zarezonansniy). To build relationships and graphical simulation modes were used following initial parameters investigated vibrating separator:

1. $r_1 = r_2 = 0,055\text{m}$ – unbalance radius (magnitude unbalance eccentricity)
2. $\omega_{1\Box} = 100\text{c}^{-1}$ – angular velocity of unbalance,
3. $M_{\text{Д}} = 3\text{kg}$ – unbalance mass,
4. $S = 0,001\text{m}$ – vertical displacement of rotation center of the unbalance of mass center,
5. $\alpha_0 = 0^0$ – initial angle position of unbalance.
6. $L = 0,25\text{m}$ – length of the suspension springs,
7. $f = 0,35\text{m}$ – vertical coordinate mounting suspension springs,
8. $b = q = 0,7\text{m}$ – horizontal coordinates attachment suspension springs,
9. $M_{K_1} = M_{K_2} = M_{K_3} = 35\text{kg}$ – weight of containers vibrating separator,

10. $C_1 = C_2 = 15,0 \text{ kN/m}$ - stiffness of the left and right suspension,

11. $I = 6,5 \text{ kg} \cdot \text{m}^2$ - moment of inertia of the container.

Here are some graphic impact parameters depending on the magnitude of vibration separator vertical component amplitude point O_6 - "Geometric center" of separator. In Fig. 3 shows the effect on the vertical component of the amplitude oscillatory mass at variable angular velocity of rotation of the drive unbalance and stiffness of the suspension. Size oscillatory mass varied by adding containers vibrating separator equal portions granular mixtures for separation. The value of the angular velocity about is varied by changing the driving induction motors with different speed. The stiffness of the suspension changed the separator as in steps, by installation of a separator has one additional spring with stiffness, hardness suspension springs, and by removing one of the three springs on the left and right suspension towers separator.

From these dependencies can draw the following conclusions:

a) the value of the amplitude of vibration separator nonlinearly depends on the weight of containers and the environment and it is reduced to its growth;

b) oscillation amplitude of vibrating separator container nonlinearly dependent on the angular velocity of the drive and unbalance increases with a decrease;

c) the amplitude of the oscillations of a vibrating separator container nonlinearly dependent on the stiffness of the suspension vibratory separator - decreases with its increase.

On the basis of theoretical research can construct a series of curves directly dependent on the amplitude unbalance radius of the container (or mass or static unbalance moment), the rigidity of the suspension or the angular speed of the drive in various combinations with each other. Thus in Fig. 4 shows the dependence of the vertical component of the amplitude of vibration separator depending on the radius of unbalance in its various masses. Dependencies are built with fluctuating weight of the container 84 kg, angular velocity unbalance 141 s^{-1} , and the rigidity of the suspension 34290 N/m .

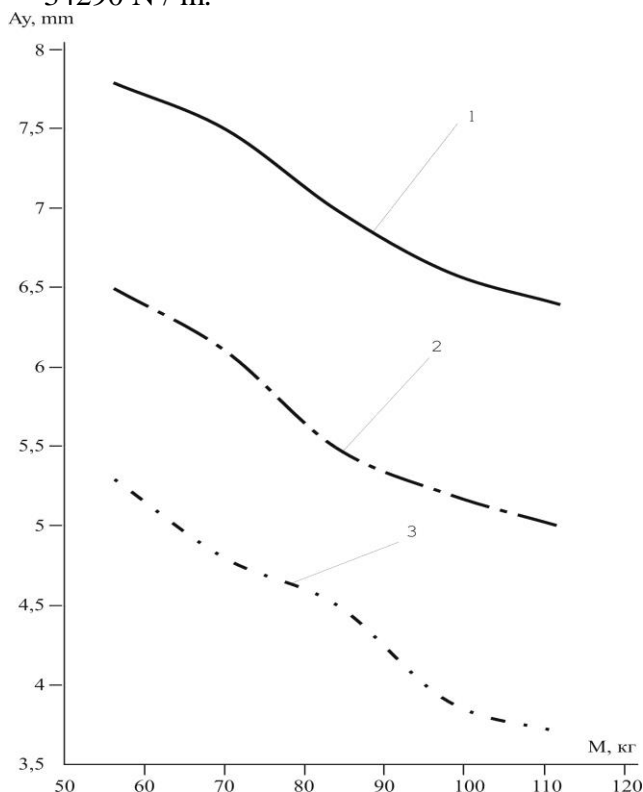

Fig. 3 Dependence of the vertical component of the oscillations of a vibrating separator of oscillatory mass at angular velocity unbalance: 1 - suspension stiffness (left or right) 22860 N/m ; 2 - 34290 N/m 3 - 45710 N/m

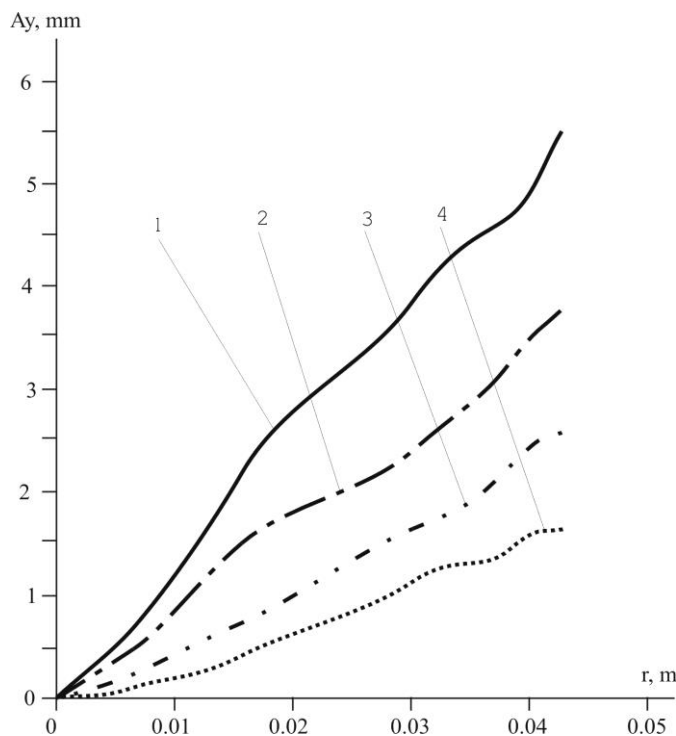

Fig. 4. Dependence of the vertical component of oscillation of a vibrating separator radius of unbalance:

1 - 9.238 kg mass unbalance, 2 - 6,927 kg, 3 - 4.618 kg, 4 - 2.309 kg.

Analyzing the obtained dependencies can be concluded:

- a) the amplitude of the oscillations of a vibrating separator nonlinearly depends on the radius of unbalance and increases with its increase;
- b) the amplitude of the oscillations of a vibrating separator nonlinearly depends on the mass unbalance and increases with its increase;
- c) should note the is the ability to change these two parameters in the operation of the vibrating separator and the significance of their impact on the intensity of the process of vibratory separation.

In Fig. 5 is given depending on the amplitude of the vertical component of the geometric center of the vibratory separator angular velocity unbalance for different values of the unbalanced mass (mass unbalance). Oscillating mass in this case is 84 kg, suspension stiffness 34,290 N / m, the radius of unbalance 0.0424. As shown in the graphical dependencies nonlinear oscillation amplitude decreases with increasing angular velocity unbalance.

In Fig. 6 shows the dependence of the vertical component of the amplitude of vibration separator on the hardness of the suspension at different radii unbalance in these parameters vibrating separator: fluctuating weight - 84 kg, 9.238 kg mass unbalance, unbalance angular velocity of 141 s⁻¹. Graphic dependences show that the amplitude of the vertical oscillations of a vibrating separator nonlinearly dependent on the rigidity of the suspension and its increase is reduced.

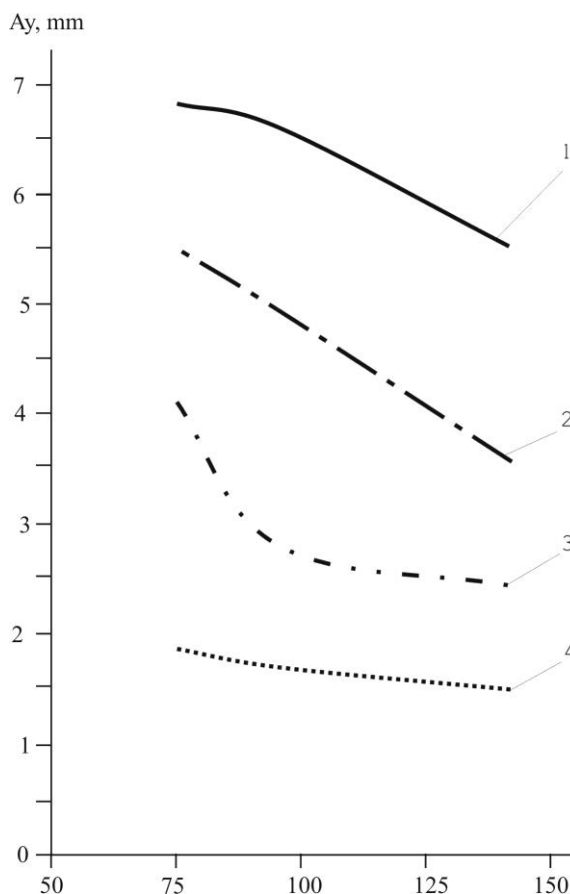

Fig. 5. Dependence of the vertical component of the oscillations of a vibrating separator angular velocity unbalance 1 - 9.238 kg mass unbalance; 2 - 6,927 kg; 3 - 4.618 kg; 4 - 2.309 kg.

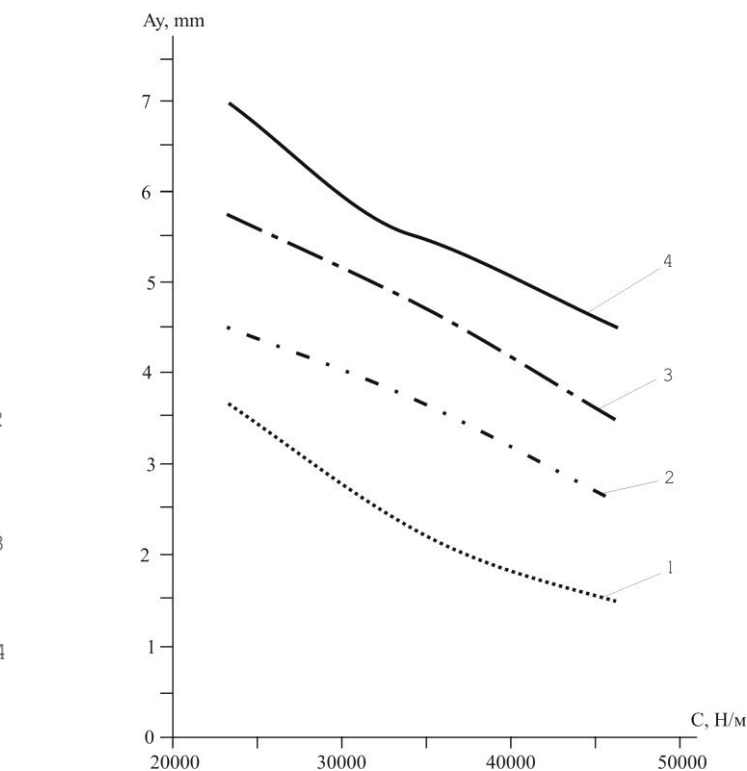

Fig. 6. The dependence of the vertical component of the oscillation of containers vibrating separator of suspension stiffness: 1 - radius of unbalance 0.0162 m; 2 - 0.03 m; 3 - 0.0392 m; 4 - 0.0424 m.

Thus, the parameters of vibration separator (the value of oscillatory mass unbalance radius, mass unbalance, suspension stiffness), depending on the amplitude of which have been mentioned above, can be considered when choosing the basic modes of vibration separator - they cause a significant impact on the nature and amplitude of oscillations of a vibrating container separator, and, correspondingly, the intensity of separation of bulk materials. Adjust and change these parameters is relatively simple. In addition, the magnitude of the amplitude of vibration separator is

influenced by the size of the working container vibratory separator, the attachment of the working suspension and unbalance. Therefore, these factors need to be considered at the design stage of a vibrating separator. In Fig. 7. are dependent amplitude of vibration separator horizontal coordinates of its suspension mount (sum values b and q in Fig. 2) with respect to the moving coordinate system associated with containers separator.

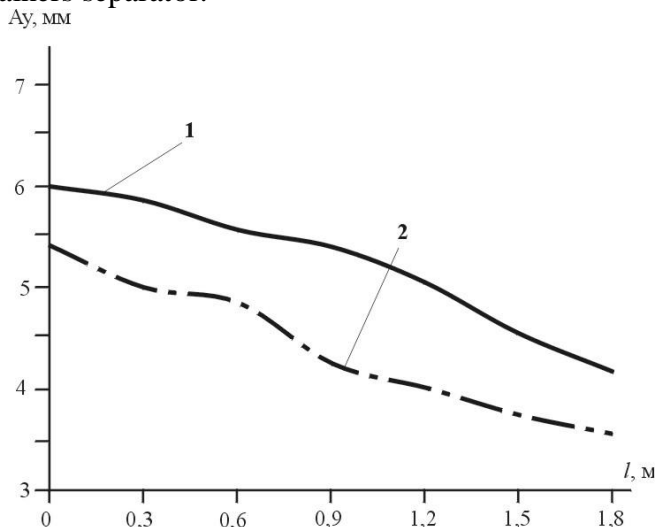

Fig. 7. The dependence of the amplitude of vibration separator container from the suspension arrangement: 1 - fluctuating weight 70 kg, 2 - fluctuating weight 84 kg.

As shown in Fig. 7, with increasing distance between supports vibrating separator (the distance between the left and right seat), the amplitude of oscillation of the container at constant other parameters vibratory separator decreases.

Thus, when we make the analysis of the theoretical results and graphical dependence (Figure 3. - Figure 7), we take the following modes and parameters of the vibratory separator with three containers that will provide the fastest separation unit volume of bulk mixture per unit time:

- a) containers vibrating separator place vertically one above the other, thereby reducing the distance between the supports and increase the vibration amplitude at constant other parameters (as in Fig. 7);
- b) rigidity of working suspension - total N / m;
- c) angular velocity of unbalance 141s⁻¹ (oscillation amplitude in this case is equal to 7.8 mm, which is less magnitude than the angular velocity at 95s⁻¹ - 8,0 mm or angular velocity unbalance 75s⁻¹ - 8.2 mm. however, products of square amplitude in cubic angular velocity will unbalance respectively -, - according to universal optimization criteria [1]);
- d) unbalance weight - 9,238 kg;
- e) radius of unbalance - 0.0424 m (static unbalance moment 0.3921 kg m.);
- f) distance between supports - 1,1 m.

Conclusion.

Study of dynamic processes in vibratory separators based on mathematical modeling of an actual application tasks - it makes it possible to study the combined effect of parameters of vibrating separator and loose environment that needs separuvaty (in different combinations with each other) on the intensity of separation, allowing the design stage to reduce vibratory of separators experimental studies, which differ in significant material and time constraints.

In this paper, in particular, to simulate selected vibratory separator with three working containers, supple suspension and unbalanced drive, which has several advantages over other separators are characterized by simplicity of of designs and maintenance, low sensitivity to the properties of the medium, which is separated, a variety of forms of vibrations, the possibility discharging the mixture after separation by separate factions and process automation.

Developed unified vibratory separator parameterized model can be used (by changing its parameters or vanishing) for a wide range of structures vibrating separators as three working containers and separators for two or one working containers with a variety of their relation to each

other and the frame or suspension of the separator. Using a database of ready uniform mathematical models can reduce the duration of studies and design of vibrating separators, reduce material costs in general.

Based on the constructed dependency are making the recommendations on the choice of parameters of vibrating separator with three working containers, spring suspension and unbalanced drive that will provide the greatest intensity of separation processes in it.

1. Subach AP Dynamics of processes and machines объёмной processing. - Riga : Zinatne , 1991. - 240 p. 2. Opirskyy BJ, Denisov PD New Projects vybratsyonnyye machines, konstruyrovanye and calculation. - Lviv : Mir, 1991. - 158 p. 3. Serduk LI Managed vybratsyonnyye mashyny with debalansnyty vybrovobudytyamy oscillations // Kiev: Ukrainian Scientific- Technical Journal " Vibrate in Technics and Technology ". - 1994. - № 1. - P. 31-35 . 4. Stocki ZA , Topilnytskyy VG, Cusi JM " A mathematical model describing the dynamics of unbalanced vibratory separator drive ," Automation of production processes in engineering and instrument making. Interdisciplinary collection of scientific papers. - Lviv : Publishing House of Lviv Polytechnic. - 2013 . - Vol. 47. - P. 28-36 . 5. Mytropolskyy JA, Moseenkov BI Asymptotycheskye solutions to equations chastychnyh proizvodnyh . - K. : High School , 1976. - 592 p.