

## **CONCEPTION OF SIX-AXIS JOYSTICK**

© Gajda A., Krawiec P., 2013

**At the beginning of this article authors show limitations of currently used solutions in the field of reliable and safe working machines mechanical arms steering systems. There is also presented a conception of six-axis joystick which could be used to test new solutions in mentioned application. Presentation show main mechanical and measuring sub assemblies. Deficiencies and constraints of proposed construction were also discussed. Future works and plans were described at the end of article.**

**Key words: joystick, multiple-axis joystick.**

**На початку цієї статті автори описують обмеженість використовуваних сьогодні рішень в галузі надійних і безпечних робочих машин, механічних рук, систем управління. Також наведено концепцію джойстика з шістьма осями, який можна використовувати для тестування нових рішень у певних застосунках. Презентація показує основні механічні та вимірювальні складові одиниці. Було також обговорено недоліки і обмеження запропонованої структури. Плани для майбутньої роботи описано наприкінці статті.**

**Ключові слова: джойстик, джойстик з кількома осями.**

### **Introduction**

Every change concerning working machines steering systems which are produced at global scale, is very expensive and time-consuming. The reason of that is necessity of carrying out experiments to verify reliability, safety and ergonomics applied modifications. On the other hand better collaboration between operator and human-machine interface (HMI) cause significant increase of efficiency and reduction of mistakes being made during work [3; 5].

These are the reasons of increased focus of attention in the field of multiple axis joysticks, which could be used to control excavators mechanical arm for example [1; 2]. That is because the great advantage of multiple axis constructions over traditional solutions where the most common are two-axis joysticks, is that they make use of human hands incredible movement capability [2-4]. There can be seen many examples of multiple-axis joysticks being used in other branches of industry. Good examples are six-axis construction by Hendrik Machiel Van der Loos from 1983 [7], dedicated for disabled people to manipulate a robotic arm, or nowadays surgical robots like DaVinci or Zeus (comparison: [6]).

The aim of this paper to present the conception of six-axis joystick, which would allow to conduct multiple researches with usage of different sensors sets. It is assumed that prototype of this conception of joystick will be used as a test stand, as well as in educational purposes.

### **Construction**

The main goal for the construction is the ability to take measures of movement in all six decreases of freedom: shifts and rotations over X, Y and Z axes (fig. 1). In this case, joystick would be fully compatible with human hands ability to move.

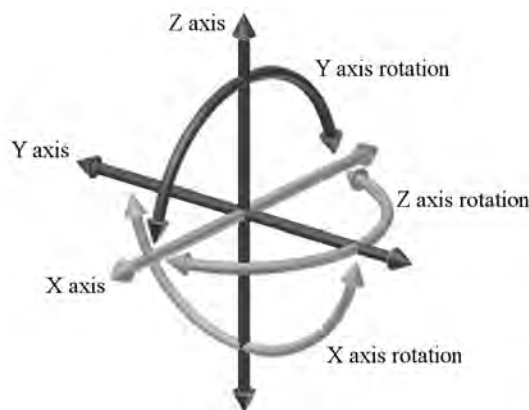

*Fig. 1. Shifts and rotations measured by joystick*

It is assumed that the major usage will be concerned with conducting experiments and teaching. For that reason it was decided to take advantage of many different ways to measure displacement among various axes.

As far as the shape of joystick is concerned, classical variant was chosen. It was determined by further establishments related with studies, where the purpose would be to compare various joystick setting solutions with regard to quality and efficiency of operators work.

### **1.1. Technical assumptions**

All restrictions put on project of joystick construction are result of earlier accepted assumptions, described at the beginning of this section (see p. 1). It is essential for the whole construction, that there is a possibility to disassemble it or make modifications in any time (for example: when one want to change sensors). This is also the reason for used parts and materials limitations. These should be easy to obtain and it must not be hard to modify them.

### **1.2. Sensors**

All sensors are connected to programmable micro-controller, which serves as a motherboard. This solution enables to create unlimited signal on the output. It will be also easier to replace any sensor, because the major changes would only concern the program in the micro-controller.

### **1.3. Distribution of tasks**

The whole construction (fig. 2) is divided into separate modules, where each can be disassembled and is responsible for measuring different kind of displacement. The purpose behind this solution is to make change of sensors easier or create the possibility to remove the module if one does not need it.

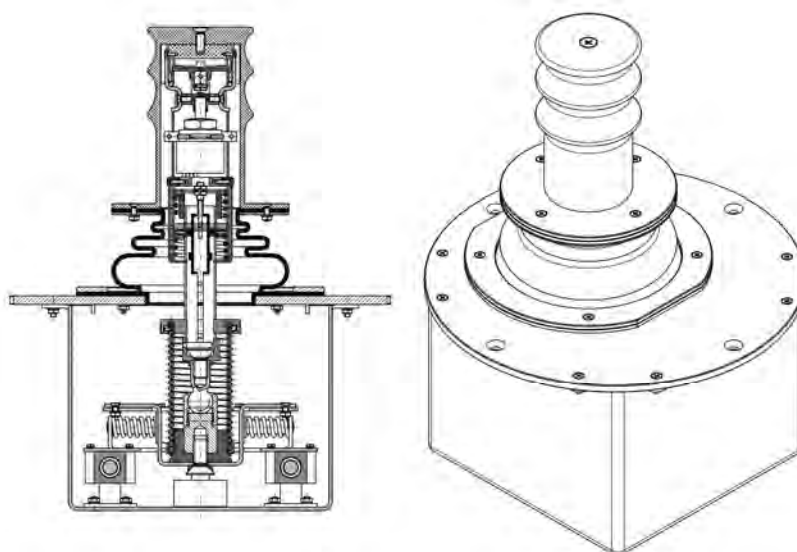
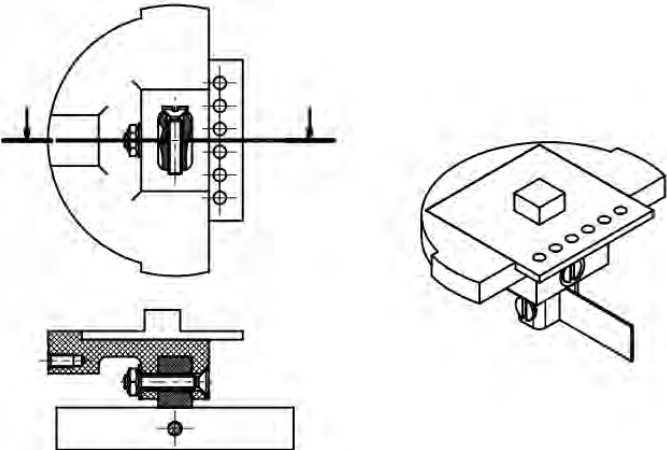

*Fig. 2. Construction of the joystick*

The housing is not the necessary part for the joystick to work properly. It is assumed, that in the experimental mode joystick can be closed for the subject, where in the teaching mode it could be opened for better understanding of the working construction.

**1.3.1. X and Y axis rotation**

Measurement of the X and Y axes rotation is taken by ADXL335 accelerometer, which is situated at the top of the rod (fig. 3). There is possibility, that joystick would work in a position, where it s not situated parallel to the ground. To prevent a situation in which there is a possibility of false reading of the rod position, motherboard contain another, the same accelerometer. Now the signals from both sensors can be compared and the location of rod is established with regard to operators position—not the ground.

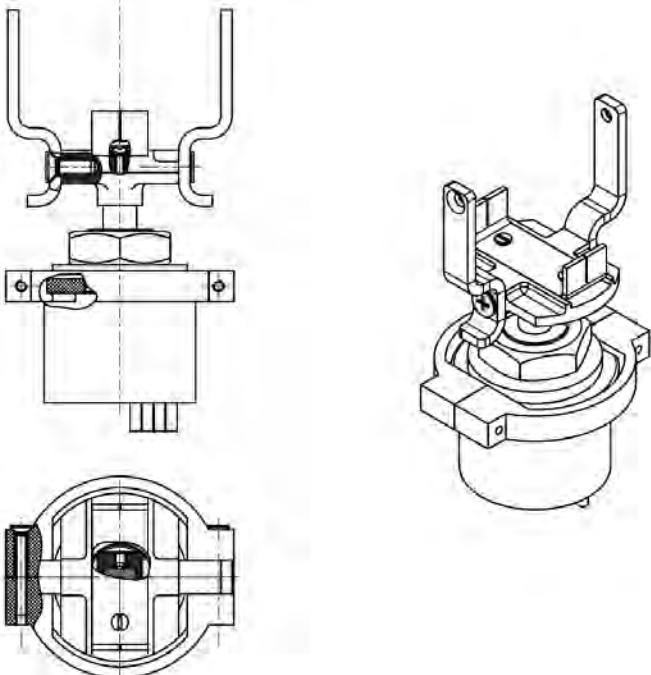

*Fig. 3. X and Y rotation measurement module*

The proper movement of the module is secured by ball joint, which is mounted to the set responsible for X and Y shifts measure (fig. 6). Spring around the ball joint enables the rod to return to its initial position.

**1.3.2. Z axes rotation**

Rotation around Z axes is measured by HSM30 Sakae sensor. The whole module with mounting of the sensor is shown in the figure 4. Responsible for the return to its initial position after a displacement is the flat spring mounted to the bottom of the X and Y rotation measure module, shown in the figure 3.



*Fig. 4. Z axes rotation measurement module*

### 1.3.3. Z axes shift

Displacement along Z axes is measured by 5903 Spectrum sensor. The measuring module with mounting of the sensor is shown in the figure 5. Two springs situated on the rod are responsible for returning the joystick to its initial position (fig. 5).

### 1.3.4. X and Y axis shift

ADNS-2051 Avago optical unit measures displacement along X and Y axis. It is commonly used in optical mice. Whole module is shown in the picture 6. The return to initial position is possible thanks to springs situated on each shaft, where there are two shafts for each axes. This solution should guarantee proper stiffness of the whole module.

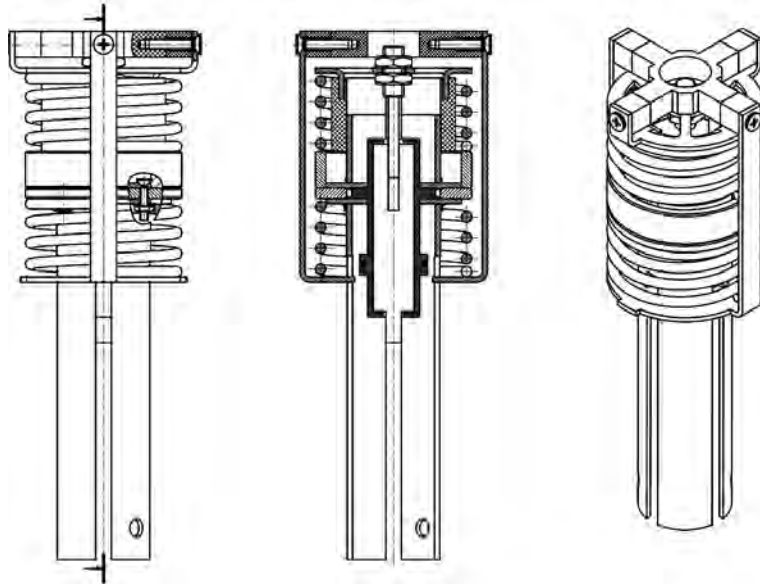

Fig. 5. Z axes shift measurement module

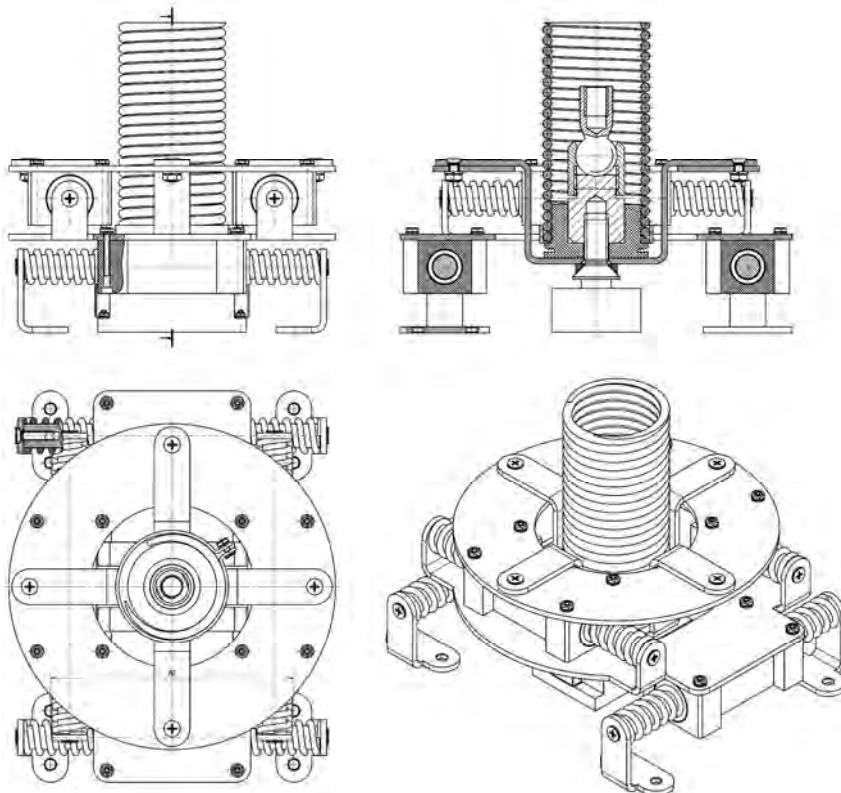

Fig. 6. X and Y axis shift measurement set

The sensor is situated below the ball joint. Stiffness is required, because the position sensor can not hit, nor can it move away from, the the bottom of the housing.

### Discussion

There are few difficulty issues concerned with the presented construction. At first, when the joystick is used with the housing, it is impossible to make move along, for example X axis and in the same time tilt it around Y axis. This is because the rod would hit the case.

Another point is that it is unknown if the range of movement of the rod agrees with the range of movement of the operators hand. This is also concerned with the force which one should apply to move the joystick along, for example only X axes. There is possibility that it would be impossible because of the position of the operators arm, which is by default situated on the non-moving armrest. For example, the alternative solution is presented in Van der Looses [7] construction (which was mentioned earlier), where the forearm moves along with palm on special base. However, this is concerned with further complication of the construction.

Another job to do is selection of the characteristics of used springs. In our opinion, the proper way to achieve that is to carry out an experiment with the representative group of people. This would allow to select the best set of parameters of each spring, considering the easiness of moving the joystick in any direction.

### Future work

Authors claim, that presented conception is a solid base for developing and building a prototype of the joystick. Unsolved issues demand carrying out proper researches (for example the characteristics of spring mentioned at the end of section 3). It is obvious that process of making prototype, would require unavoidable changes to the project. In fact, this is the next intended step. A test stand is build, which would give opportunity to check and analyze the working of the joystick.

It is also assumed, that further in research, the construction will become simpler. The condition of possibility to disassemble every module in the joystick, which was mentioned at the beginning (see section 2), is very often the reason of choosing more complicated solutions.

*1. Branczyk Ch. What makes load handling so difficult? International Journal of Forest Engineering, 7(3), 1996. 2. Elton M.D. and Book W.J. Comparison of human-machine interfaces designed for novices teleoperating multi-dof hydraulic manipulators. In RO-MAN, 2011 IEEE, 2011. 3. Matthew E. Kontz. Haptic control of hydraulic machinery using proportional valves. PhD thesis, Georgia Institute of Technology, 2007. 4. Lawrence P.D., Salcudean S.E., Sepehri N., Chan D., Bachmann S., Parker N., Zhu M. and Frenette R. Coordinated and force-feedback control of hydraulic excavators. Experimental Robotics IV, 223:181–194, 1997. 5. Salcudean S.E., Hasht rudi-Zaad K., Tafazoli S., DiMaio S.P. and Reboulet C. Bilateral matched impedance teleoperation with application to excavator control. Control Systems, IEEE, 19(2):29–37, 1999. 6. Gill I.S., Sung G.T. Robotic laparoscopic surgery: a comparison of the da vinci and zeus systems. Urology, 58(6), 2001. 7. H.F. M. Van der Loos. Design of a six-axis input device for a robotic manipulation aid. In Proceedings of the RESNA Annual Conference, 1983.*