

<https://doi.org/10.23939/jtbp2020.01.016>

Vasyl Zhelykh, Yurii Furdas, Khrystyna Kozak, Maksym Rebman

RESEARCH ON THE AERODYNAMIC CHARACTERISTICS OF ZERO-ENERGY HOUSE MODULAR TYPE

*Department of Heat and Gas Supply and Ventilation,
Lviv Polytechnic National University
cr__i@ukr.net*

Ó Zhelykh V., Furdas Y., Kozak K., Rebman M., 2020

There is a great deal of research involved in designing zero-energy buildings and engineering systems for them, however, there is little research to determine the amount of heat absorbed by wind flow from the surface of energy efficient and passive houses. The purpose of this scientific work was to evaluate the effect of wind pressure on the surface of a zero-energy building depending on the direction of flow around the air stream. To that end, it was created hollow building model in scale 1:16. Aerodynamic research were carried out in subsonic wind tunnel at Lviv Polytechnic National University.

Because of carrying out a number of experiments, aerodynamic coefficients on the surface of the house, ventilation openings at different angles of airflow, namely, $\alpha=0^\circ$; 90; 180; 270, to the house were determined. Plots of distribution of aerodynamic coefficients are obtained which allow to choose rational orientation of the house during its design.

Key words: zero-energy building, passive house, subsonic wind tunnel, aerodynamic coefficient, angle of airflow

Introduction

Increasing population, migration from place to place, high cost of housing and utilities are forcing new alternative solutions to address the problems of society. In turn, this creates the preconditions for creating new engineering solutions. Not only traditional energy sources, but also the widespread use of non-traditional energy sources, it is possible to introduce energy-efficient construction as a promising area in the construction industry.

Studying energy efficient and passive construction allows you to combine the expertise of different construction industries and, as a result, to get a complete complex to meet public needs.

One of the solutions to the complex problem is a passive house (German Passivhaus) - a building, the main feature of which is the lack of need to use heating or low energy consumption, on average, about 10% of the specific energy per unit volume consumed by most modern buildings. In the prevailing number of developed countries there are own requirements for the passive house standard.

In Ukraine, according to (DSTU-NB A.2.2-5, 2007) "Passive" is considered to be a house which energy consumption for heating is no more than 10–15 kW·hour/(m²·year). According to the (Law of Ukraine, 2017), a building with close to zero energy consumption is considered to be a building with a level of energy efficiency that exceeds the established minimum requirements, in which energy from renewable sources is used mainly for the formation of proper living and living conditions of people (Basok et al., 2013; Zelykh et al. 2016).

Reduction of energy consumption in energy efficient buildings and zero energy buildings is achieved by reducing the heat loss of the building, ie the increase of wall thermal insulation, the absence of cold bridges in materials and junctions, the correct geometry of the building, zoning, and orientation around the world (Yurkevych & Savchenko, 2010; ASHRAE Handbook, 1997).

Unfortunately, however, no studies have been conducted on the external aerodynamics of passive and zero-energy buildings, which can be influenced by wind stresses depending on the orientation of the building around the world (Retter, 1984; Simiou & Scanlan, 1984).

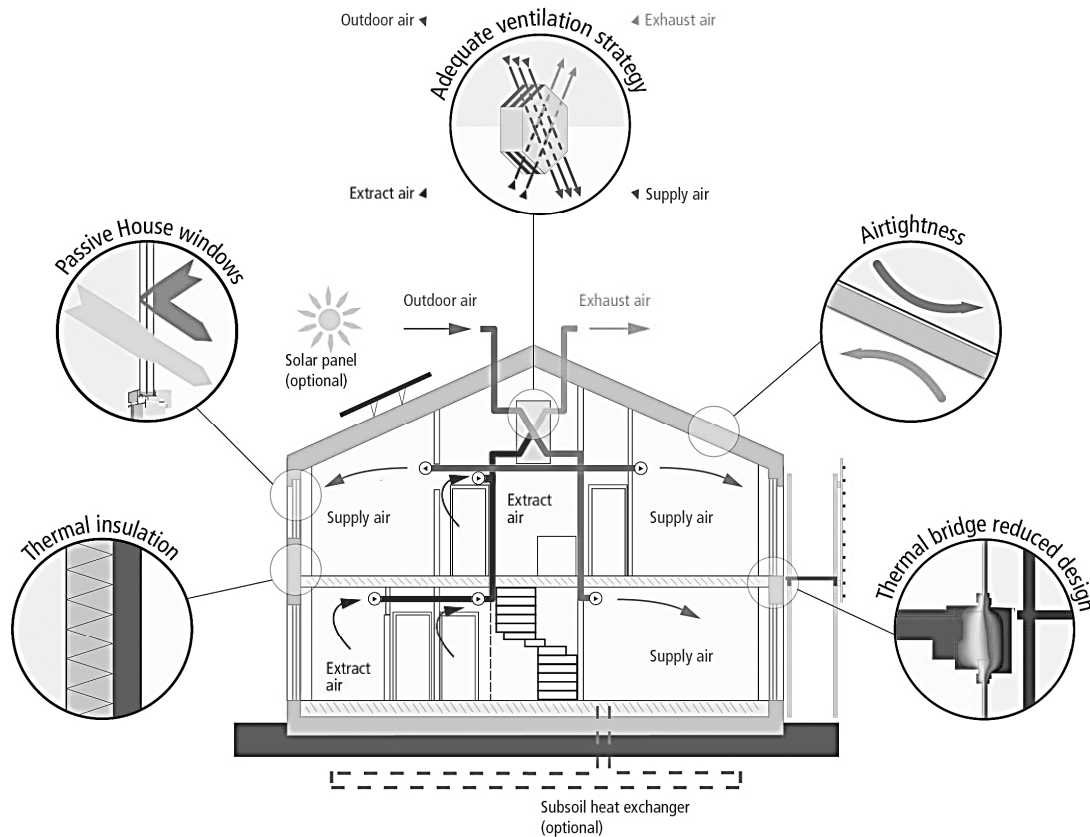

Fig. 1. Passive house basics

Building aerodynamics is an important tool for determining the effects of wind flows on a building, taking into account the terrain. When the directions of the flow around the building change, the nature of the wind flow changes, which is caused by the change in the shape of the houses, so there is a need for special studies in the wind tunnel. Aerodynamic studies make it possible to determine the effect of terrain on the distribution and value of aerodynamic coefficients on the surface of a model house, as well as the influence of the model on the distribution of pressure on the surface. The issue of heat selection by wind flow over the surface of energy efficient and passive homes has not been sufficiently studied.

Target of this article

To assess the impact of wind pressure on the surface of the zero-energy house, depending on the flow direction of air flow. Obtaining plots on the surface of the house and the distribution of aerodynamic coefficients.

Techniques used

Aerodynamic studies were carried out in a subsonic wind tunnel at Lviv Polytechnic National University with an open working part with a diameter of 1 m.

1. The surface was divided by a coordinate grid with cells 40×40 mm. The letter axes are located perpendicular to the windward facade of the model of the house, the numerical axis – in parallel.

2. At the second stage, the distribution of aerodynamic coefficients on the surfaces of the hollow model of the building (projected roof, thermosiphon collector, windward and leeward facades) was

studied. For this purpose, the locations of transverse sections were conditionally determined (from 1-1 to 12-12), in which holes were drilled at the level of each cell and mounted into the models tubes.

3. Investigations were carried out at three different airflow velocities in the range $V_{\infty} = 7-10$ m/s. The pressure measured at the drainage points was recorded by a micromanometer 10.

4. The velocity of the undisturbed flow V_{∞} in the working part of the pipe was determined by the pressure in the pipe chamber and specified by the value of the dynamic pressure in the working part of the pipe, which was measured using a pneumatic tube and micromanometer 10.

5. Studies were also conducted for the directions of the incoming air flow to the model $\alpha = 0^{\circ}; 90; 180; 270$.

6. According to the results of aerodynamic studies, spatial plots of the distribution of aerodynamic coefficients on the flat surface of the model lining were constructed for the directions of the incoming air stream $\alpha = 0^{\circ}; 90; 180; 240$ where the house is not conventionally shown and the graphs of the distribution of aerodynamic coefficients on the surface of the model in sections 1-1... 12-12 for similar angles of attack.

The investigated model on which the experiments were conducted was a modeled plot of a flat earth surface of low roughness with the zero energy model of the house, which is made in M 1:16 (Fig. 2).

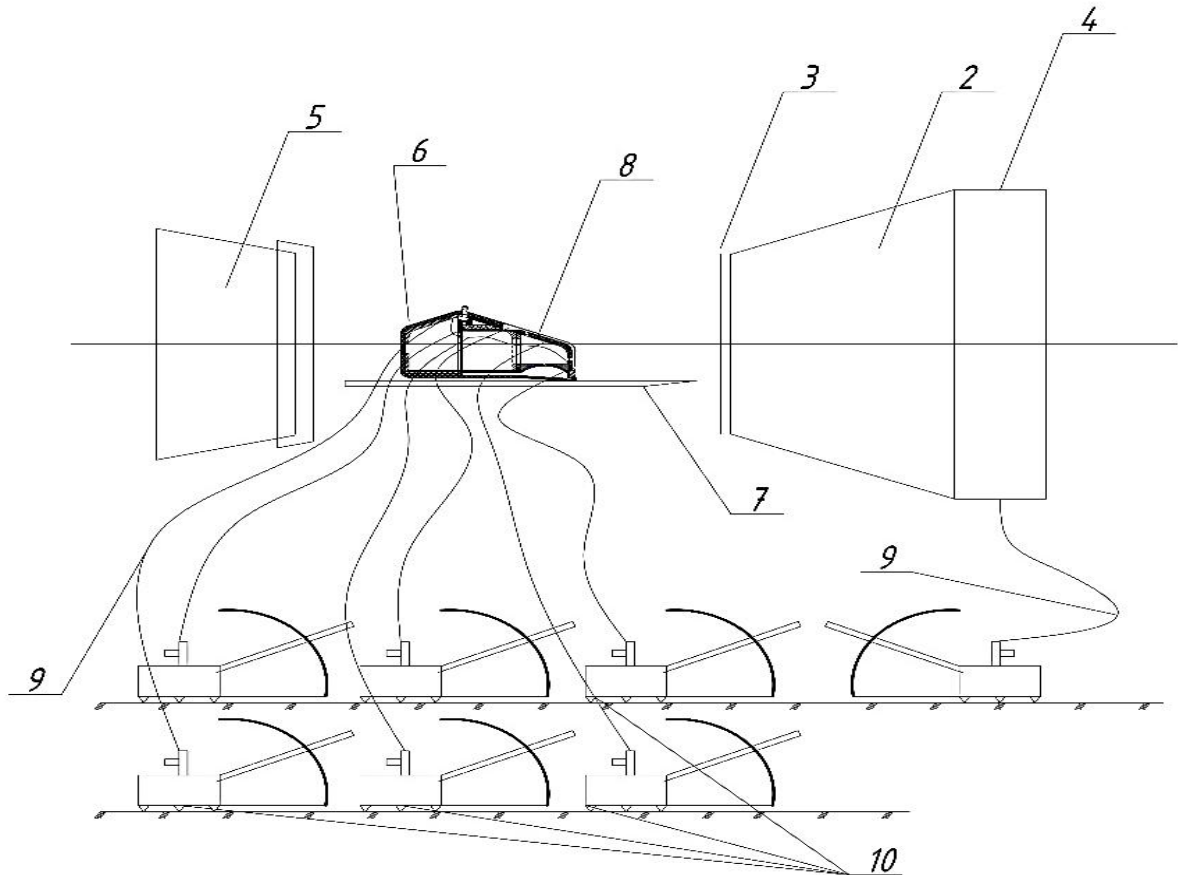

Fig. 2. Diagram of the experimental installation

1 – working part of the wind tunnel; 2 – nozzle; 3 – alignment grid; 4 – fork camera; 5 – diffuser;
6 – house model; 7 – the underlying surface of the model; 8 – drainage points (static pressure selection);
9 – flexible tubes; 10 – micrometers

On Fig. 3 presents a real view of the experimental model installed in the wind tunnel (Kinash et al., 1998; Zhukovsky et al., 1997).



Fig. 3. Model in the wind tunnel

In making the experimental physical model, it was decided to create a hollow 1:16 scale model. Corrugated cardboard was the main component for it. The figures show the sequence of the model (Serebrovsky, 1977; Krasnov, 1974).

Analysing the results of studies

According to the results of aerodynamic studies, plots of distribution of aerodynamic coefficients on the surface of the model house were constructed for the directions of incoming air flow $\alpha = 0^\circ; 90^\circ; 180^\circ; 270^\circ$ (Timofeev & Kuznetsov, 1996; Stasiuk et al., 1998).

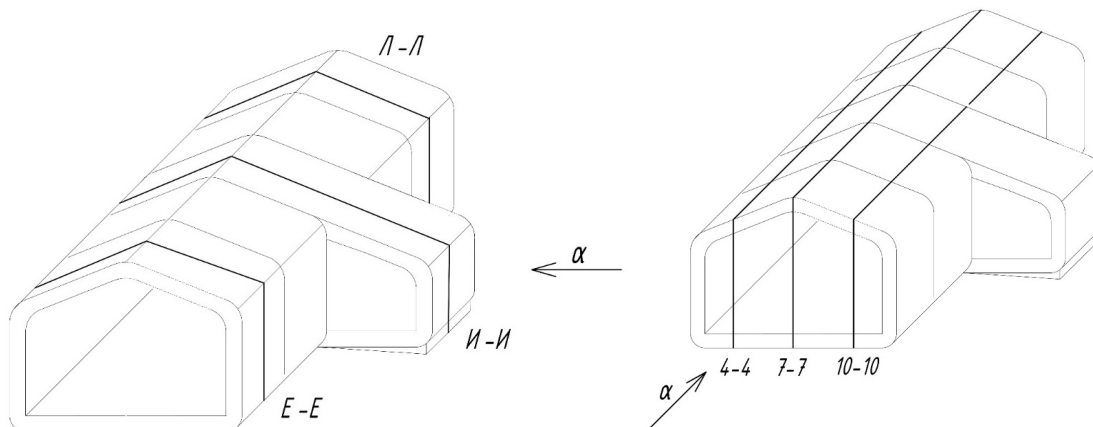

Fig. 4. Section of the house model at the incoming wind stream $\alpha = 0^\circ$ and $\alpha = 90^\circ$

It was also built wind epures for different angles of incidence of the air flow (Fig. 5, 6).

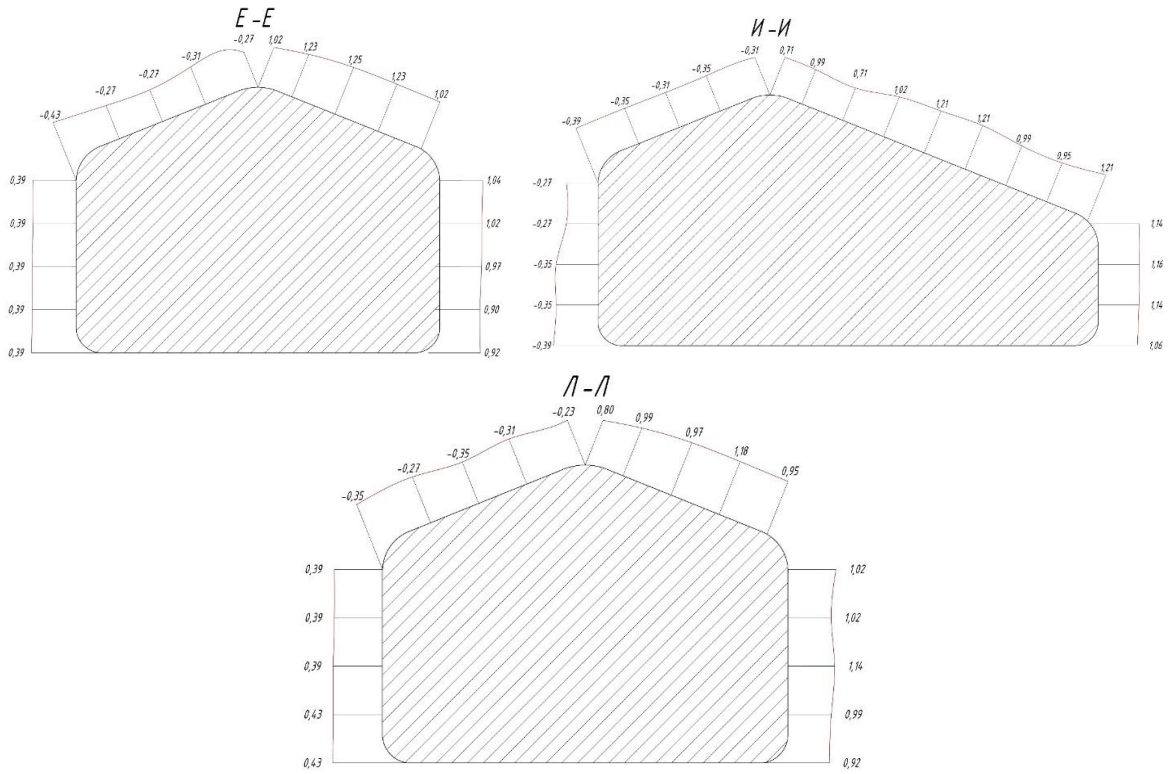

Fig. 5. Plots of the distribution of aerodynamic coefficients in section E-E, И-И, Л-Л for the direction of the incoming wind stream $\alpha = 0^\circ$.

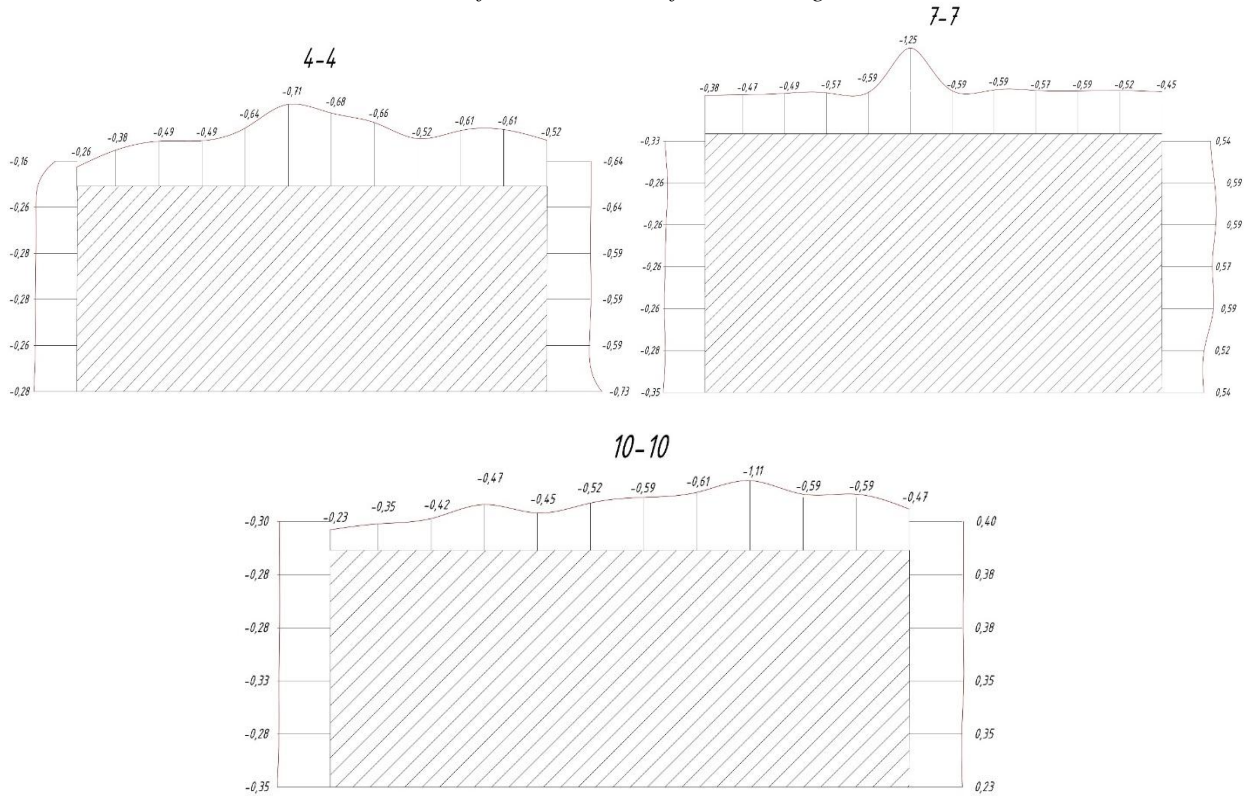

Fig. 6. Plots of the distribution of aerodynamic coefficients in section 4-4, 7-7, 10-10 for the direction of the incoming wind stream $\alpha = 90^\circ$.

Analyzing the spatial plots of the distribution of aerodynamic coefficients on the house model surface relative to the height of the model of the house, we can state:

1. In the windward region of the flat surface, there is a zone of positive values of k with a wavy increase when approaching the windward facade of the model of the house.
2. In the windward area of the roof, aerodynamic coefficients acquire a very wide range of values from 0.63 to 1.21, indicating a sharp change in wind pressures on the roof surface.
3. In the leeward area of the surface and on the leeward facade of the model, the values of the aerodynamic coefficients are negative and are in the range $-0.16 \dots -0.45$ for the flow direction $\alpha = 0^\circ$. These values are smaller than the values prescribed by the standards for the leeward house facade.
4. The diagrams of the distribution of aerodynamic coefficients are obtained, which allow choosing a rational orientation of the house during its design (Zhelykh et al, 2018).

Conclusions

1. In the windward region of the flat surface, of the underfloor there is a zone of positive values of k with a wavy increase when approaching the windward facade of the model of the house.
2. In the windward area of the roof, aerodynamic coefficients acquire a very wide range of values from 0.63 to 1.21, indicating a sharp change in wind pressures on the roof surface.
3. In the leeward region of the underfloor surface and on the leeward facade of the model, the values of the aerodynamic coefficients are negative and are in the range $-0.16 \dots -0.45$ for the direction of the incoming flow $\alpha = 0^\circ$. These values are smaller than the values prescribed by the standards for the leeward facade of the house.
4. The plots of the distribution of aerodynamic coefficients are obtained, which allow to choose a rational orientation of the house during its design.

References

- Instruction on development and drawing up of energy passport of houses at new construction and reconstruction. DSTU-N B V.2.5-35:2007. (2007). (in Ukrainian).
- Law of Ukraine "On the energy efficiency of buildings" of 22.06.2017 (2017). No. 2118-VIII. (in Ukrainian).
- Basok B. I., Khibina M. A., Belyaeva T. G. (2013). Energy efficient homes of the "zero-energy" type. The principles of creation and development. *Industrial heat engineering*, T. 35, No. 6, pp. 57–66. (in Russian).
- Zhelykh V., Kozak K., Savchenko O. (2016). Using of Thermosiphon Solar Collector in an air Heating System of Passive. *POLLACK PERIODICA*, Vol. 11, No. 2. pp. 125–133.
- Yurkevych Y., Savchenko O. (2010). Optimization of the thermal protection mode during the next indoor heating. *Scientific Journal of Lviv Polytechnic National University*, No. 677. Pp. 42–45.
- ASHRAE Handbook. Fundamentals. SI Edition. 1997. pp. 517.
- Retter E. I. (1984). *Architectural and construction aerodynamics*. pp. 294. (in Russian).
- Simiou E., Scanlan R. (1984). *Effects of wind on buildings and structures*. pp. 360. (in Russian).
- Kinash R., Zhukovsky S., Kovalenko V. (1998). Influence of relief on wind speed in mountainous areas. *Proceedings of the 1-st International. Scientific-technical Conf.* pp. 185–1886. (in Ukrainian).
- Zhukovsky S. S., Kinash R. I., Kovalenko V. A. (1997). Aerodynamic studies of a residential quarter with a dominant multi-storey plate-type building. *Scientific Journal of Lviv Polytechnic National University*, No. 335. pp. 32–41. (in Ukrainian).
- Serebrovsky F. L. (1977). *Construction aerodynamics and aeration of settlements*. pp. 73. (in Russian).
- Krasnov N. F. (1974). *Applied Aerodynamics*. pp. 732. (in Russian).
- Timofeev M. V., Kuznetsov S. G. (1996). Towards finding the aerodynamic coefficients on the surfaces of the walls of houses with the help of PC. *Construction of Ukraine*, No. 5. pp. 40–41. (in Ukrainian).
- Stasiuk M. I., Kinash R. I., Zhukovsky S. S. (1998). Model studies of surface wind speeds in mountains districts. *Scientific Journal of Lviv Polytechnic National University*, No. 360. pp. 132–141. (in Ukrainian).
- Zhelykh V., Yurkevych Y., Savchenko O. (2018). The investigation of external aerodynamics of building of unusual architectural form. *Budownictwo o Zoptymalizowanym Potencjale Energetycznym*, 7(1). Pp. 37–42.

В. М. Желих, Ю. В. Фурдас, Х. Р. Козак, М. Р. Ребман
Національний університет Львівська політехніка,
Кафедра теплогазопостачання та вентиляції

ДОСЛІДЖЕННЯ АЕРОДИНАМІЧНИХ ХАРАКТЕРИСТИК БУДИНКУ НУЛЬ-ЕНЕРГІЇ МОДУЛЬНОГО ТИПУ

© Желих В. М., Фурдас Ю. В., Козак Х. Р., Ребман М. Р., 2020

Вирішення завдань аеродинаміки будівель є важливим інструментом для визначення впливів вітрових потоків на будівлю з урахуванням рельєфу місцевості. При зміні напрямків обтікання будинку змінюється характер вітрового потоку, який спричинений різною геометрією форм будинку та рельєфу, тому виникає необхідність проведення спеціальних досліджень в аеродинамічній трубі. Аеродинамічні дослідження дають можливість визначити вплив рельєфу на розподіл та значення аеродинамічних коефіцієнтів на поверхні моделі будинку, а також вплив конструкції моделі на розподіл тисків на поверхні настелення. Оскільки питання відбору тепла вітровим потоком по поверхні енергоефективних і пасивних будинків є недостатньо вивчене, було проведено ряд експериментальних досліджень щодо обтікання будівлі повітряним потоком під різними кутами.

Експериментальні дослідження проводили на моделі будівлі, виконаній у масштабі 1:16, в аеродинамічній трубі в лабораторії Національного університету “Львівська політехніка”. Проаналізувавши отримані результати, можна стверджувати, що на навітряній області плоскої поверхні виникає зона додатних значень аеродинамічного коефіцієнта з хвилеподібним збільшенням при наближенні до навітряного фасаду моделі будинку. Для напрямку набігаючого потоку 0° в області навітряного фасаду моделі значення k поступово зростають у міру віддалення від поверхні настелювання і дещо зменшуються при наближенні до даху моделі.

Було побудовано епюри розподілу аеродинамічних коефіцієнтів, які дають можливість вибору раціональної орієнтації будинку під час його проектування. Крім того, отримано, що на підвітряному фасаді моделі значення аеродинамічних коефіцієнтів від’ємні і знаходяться в діапазоні $-0,16 \dots -0,45$ для кута набігаючого потоку $\alpha = 0^\circ$. Ці значення менші за величини, які регламентуються нормами для підвітряного фасаду будинку. А на навітряній області даху, аеродинамічні коефіцієнти набувають широкого діапазону значень від 0,63 до 1,21, що свідчить про різку зміну вітрових тисків на поверхні даху.

Ключові слова: будинок нуль-енергії, пасивний будинок, дозвучова аеродинамічна труба, аеродинамічний коефіцієнт, кут повітряного потоку