

Bohdan Kindratskyy, Roman Litvin

Lviv Polytechnic National University
12, S. Bandery Str., Lviv, 79013, Ukraine

© B. Kindratskyy, R. Litvin, 2023

<https://doi.org/10.23939/tt2023.02.044>

INFLUENCE OF WHEEL ROTATION RESISTANCE ON OSCILLATORY PHENOMENA IN STEERING DRIVE OF ELECTRIC BUS WITH ELECTROMECHANICAL AMPLIFIER

Summary. *Steering systems with an electromechanical amplifier (EMA) are a modern design solution compared to hydraulic and electro-hydraulic steering systems. Hydraulic steering amplifiers are used in the steering drives of modern trolleybuses and electric buses. If an electric motor powered from the power grid is used to drive the hydraulic pump in trolleybuses, then in electric buses, the source of electrical power is rechargeable batteries. Energy consumption to ensure the operation of the hydraulic power steering reduces the mileage of the electric bus between charging the batteries. Therefore, conducting research and substantiating the possibility of using EMA in electric buses is relevant and has important practical significance. Considering the design features of the electromechanical steering amplifier and the design of the steering axle of the Electron 19101 electric bus, a dynamic model of the drive for turning the controlled wheels of the electric bus was built on the spot. Based on the dynamic model of the drive for turning the controlled wheels of an electric bus with an electromechanical steering amplifier, a mathematical model of the drive and a stimulation model were developed in the MathLab Simulink environment for the study of oscillatory processes in the drive links when the wheels turn on a horizontal plane. The nature of the change of elastic torques in the links of the steering control drive of an electric bus with an electromechanical steering amplifier, the frequency of rotation of the rotor of the electric motor, the current strength in the windings of the rotor and stator of the electric motor, the angle of rotation of the steered wheels as a function of time was studied. It was found that the change in the moment of resistance to the rotation of the steered wheels increases smoothly, and the load on the drive links of the electromechanical power steering depends on the total gear ratio of the drive and its distribution between the gearbox and the steering rack. A decrease in the total transmission ratio of the drive leads to an increase in the speed of rotation of the driven wheels and an increase in elastic moments in the drive links. Transient processes in the electric part of the drive correspond to the characteristics of such electric motors in terms of the nature of the change and do not exceed the permissible values in terms of magnitude. It was established that the power characteristics of the electromechanical steering amplifier with the selected parameters and the electric motor can ensure the control of the wheels of the electric bus following the established requirements.*

Key words: *electromechanical steering amplifier, electric bus, simulation model, steering control, dynamic model, electric motor.*

1. INTRODUCTION

The steering system is a key system that affects traffic safety and is installed on various vehicles (electric cars, electric buses, cars (buses) equipped with internal combustion engines). If you compare the steering with the braking system, if the braking system fails, there is an alternative – the handbrake, which

can be used to stop the vehicle; in the case of steering – there is no alternative. Power steering systems with electromechanical power steering (EMP) are a modern design solution compared to the hydraulic and electro-hydraulic power steering systems that were common before. It is due to some advantages [1, 2], in particular: the response to the control command is faster than in the hydraulic system because it is performed directly by the electric motor instead of increasing/decreasing the fluid pressure in the system; an added advantage is that the EMA does not require the vehicle's engine to operate to maintain hydraulic pressure. Most of the energy is consumed by the EMA only when needed, as it turns on when torque is applied to the steering wheel by the driver. EMA does not pollute the environment compared to hydraulic.

2. RELEVANCE OF THE STUDY

Hydraulic steering amplifiers are used in the steering drives of modern trolleybuses and electric buses. If in trolleybuses, an electric motor powered from the power grid is used to drive the hydraulic pump, then in electric buses, the electrical power source is rechargeable batteries. Energy consumption to ensure the operation of the hydraulic power steering reduces the mileage of the electric bus between charging the batteries. Therefore, conducting research and substantiating the possibility of using EMA in electric buses is relevant and has important practical significance.

3. RESEARCH STATEMENT

To develop a mathematical and simulation model of the drive of the steered wheels of an electric bus with an electromechanical steering amplifier. To study the oscillatory processes in the drive links, taking into account its design parameters and the nature of the change in the force of resistance to turning the steered wheels relative to the road surface.

4. AIM AND TASKS OF THE STUDY

The purpose of the article is to substantiate the design parameters of the electromechanical steering amplifier of an electric bus and the feasibility of its use on such vehicles.

5. ANALYSIS OF RECENT RESEARCH AND PUBLICATIONS

Many works [1–10] are dedicated to the study of steering amplifiers; they cover the issue of modeling using various software products, the development of dynamic, mathematical models and experimental setups, and substantiation of the effectiveness of use in different types of drives.

In work [2], the authors listed the advantages of the electric power amplifier compared to the hydraulic power steering. Possible layouts of the electric power steering are given. The formula for calculating the active moment of resistance due to the angle of transverse inclination of the pin is derived. A system of differential equations describing the electric power steering with a worm gear is presented. The functional diagram of the electric power steering is shown.

The work [3] describes the possibility of optimal torque control of the electromechanical power steering (EPS) system, which is carried out by the driver. For this purpose, a compensator (LQG) is used, consisting of an optimal static state space controller (LQR) with reference and perturbed bias control and an optimal state space observer (LQE) with perturbation estimation. The compensator (LQG) provides active vibration damping and interference compensation. The obtained closed system shows good dynamic behavior and high resistance to external disturbances, unaccounted degrees of freedom, nonlinear characteristics of the system, and variations of installation parameters. Thus, the presented control meets the requirements for a modern steering control system and allows adapting the feeling of the steering wheel to the current driving situation.

The author [4] presented a dynamic model of the electric steering control device of a passenger car. The model was verified by a series of bench tests. The object of the study was the integrated system of electric power steering (EPS) installed on the steering column, which interacts with the steering mechanism. The results of the theoretical analysis were compared with the results of tests carried out on a

specially built research stand, which fully reflects the work of the assistant in the car. A satisfactory level of agreement was obtained between the model results and bench tests. System management is implemented without the use of additional sensors [5].

In [6], a model for a steering control system (SbW) consisting of a model of the steering rack unit (SRU) and a model of the steering feedback unit (SFU) was modeled and detailed analysis was performed. The model was subjected to a comprehensive analysis and reflected all the characteristics of a real SbW system. Both parameter dependencies and dominant characteristics of the SbW system are determined. It is shown that the dynamic behavior of the SRU is dominated by viscoelastic wheel mounts. The author [7] performed a dynamic analysis of the power steering system, which is modeled as a four-mass electromechanical system with the main emphasis on the mechanical part. The subject of the study is creating a model that can find application in steering control technology to simulate the feeling of steering a mechanically connected system.

Rear wheel steering can be used for a vehicle with electromechanical power steering to position the rear wheel angle. The wheel can experience significant forces not only from the engine but also from the road. However, depending on the system configuration, the motor usually cannot have a reverse drive. If it is not taken into account in the modeling process, the system model may allow reverse motion and give erroneous results. In [8], various methods of behavior implementation were investigated using the modeling of connection graphs without using backtracking.

In [9], studies concerning the efficiency of steering control and the safety of EPS systems are presented. Dynamic models of EPS systems were developed; in particular, the P-EPS model for torque estimation and the simplified C-EPS control model were described, and models were also developed taking into account different driving conditions (parking, transition from parking to driving at low speed, nominal or high speed). Depending on the vehicle speed, the force of the reaction to the road changes, showing a non-linear behavior. In addition, the conditions of the experimental tests are presented, including a description of the maneuvers on the test track and the characteristics of the tested car (electromechanical system and special sensors for measurements).

The author [10] carried out an analysis of the calculation methods of vehicle steering control systems. The dependence of the turning resistance moment of the tire in place on the turning angle of the controlled trolley wheel at the maximum permissible axle load was obtained. The mechanical parameters of the electric steering control amplifier of the trolleybus are determined.



Fig. 1. Structural scheme of the electromechanical power steering: 1 – steering wheel; 2 – upper part of the steering shaft; 3 – gear motor; 4 – lower part of the steering shaft; 5 – steering rack; 6 – tip of the steering rod

However, in the works known to us, devoted to the study of the operational characteristics of electric power steering amplifiers, the flexibility of the links of the steering mechanism is not taken into account, which does not make it possible to assess the influence of the resistance of the steering wheels on the load of the drive links and the feasibility of using electric amplifiers in electric buses; therefore, additional research is needed.

6. PRESENTATION OF BASIC MATERIAL

The electromechanical power steering (Fig. 1) consists of the following main elements: an electric motor, a control unit, a steering shaft gear, a toothed rack, a steering shaft, an amplifier gear, a torque sensor on the steering wheel, and a wheel angle sensor [11].

We will use its dynamic model, presented in Fig. 2, to study the oscillatory processes in the steering drive of an electric bus with an electromechanical amplifier.

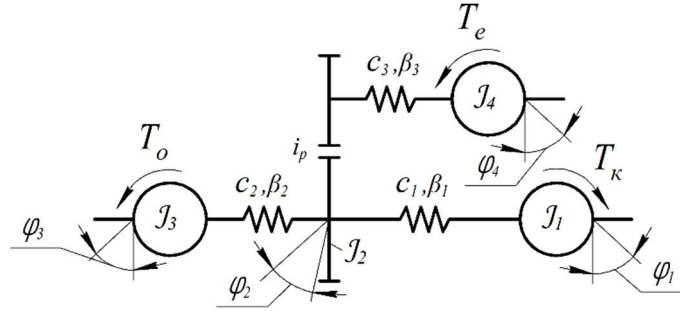

Fig. 2. Model of electric bus steering drive with electromechanical amplifier

In Fig. 2, the following notations are used: J_1 – moment of inertia of the steering wheel; J_2 – reduced moment of inertia of the part of the steering shaft to the gearbox gear; J_3 – reduced moment of inertia of the steered wheels to the worm at the end of the steering shaft; J_4 – moment of inertia of the electric motor rotor; φ_1 – angle of rotation of the steering wheel; φ_2 – angle of rotation of the gear wheel; φ_3 – turning angle of the controlled wheel in the horizontal plane; φ_4 – rotation angle of the rotor of the electric motor; c_1 – torsional stiffness of the part of the steering shaft from the steering wheel to the gearbox gear; c_2 – reduced torsional stiffness of the drive links from the wheel of the electric bus to the driven part of the steering shaft; c_3 – torsional stiffness of the rotor of the electric motor; β_1 – coefficient of energy dissipation in the steering shaft; β_2 – coefficient of energy dissipation in the drive links from the gear wheel to the driven wheel of the electric bus; β_3 – coefficient of energy dissipation in the electric motor; T_k – torque on the steering wheel; T_o – reduced moment of resistance to turning the steered wheel to the steering shaft; T_e – torque of the electric motor of the amplifier.

Mathematical model of electric bus steering wheel drive with electromechanical amplifier. We will use Lagrange's equation of the 2nd kind to derive the equations of motion of the masses of the dynamic model (Fig. 2):

$$\frac{d}{dt} \left(\frac{\partial T}{\partial \dot{q}_i} \right) - \frac{\partial T}{\partial q_i} + \frac{\partial P}{\partial q_i} + \frac{\partial F}{\partial \dot{q}_i} = Q_i, \quad (1)$$

where T – total kinetic energy of the model; P – total potential energy of the model; q_i – generalized coordinate (rotation angles of model masses); \dot{q}_i – time derivative of the generalized coordinate; F – energy dissipation function in the system links; Q_i – external generalized force factor; n – number of generalized coordinates of the model.

The rotation angles of the concentrated masses of the drive model are selected for the generalized coordinates of the system (see Fig. 2).

The following are accepted as external force factors: T_k – torque applied by the driver of the vehicle to the steering wheel; T_o – torque from the forces of resistance to turning the wheel, reduced to the steering shaft; T_e – torque created by the electric motor of the power steering.

The change in the kinetic energy T of the model, the potential energy P of the model, and the energy dissipation function in the links F of the model will be presented in the form of the following dependencies:

$$T = \frac{J_1(\dot{\varphi}_1)^2}{2} + \frac{J_2(\dot{\varphi}_2)^2}{2} + \frac{J_3(\dot{\varphi}_3)^2}{2} + \frac{J_4(\dot{\varphi}_4)^2}{2}; \quad (2)$$

$$P = \frac{C_1(\varphi_1 - \varphi_2)^2}{2} + \frac{C_2(\varphi_2 - \varphi_3)^2}{2} + \frac{C_3(\varphi_4 - \varphi_2 i_p)^2}{2}; \quad (3)$$

$$\Phi = \frac{\beta_1(\dot{\varphi}_1 - \dot{\varphi}_2)^2}{2} + \frac{\beta_2(\dot{\varphi}_2 - \dot{\varphi}_3)^2}{2} + \frac{\beta_3(\dot{\varphi}_4 - \dot{\varphi}_2 i_p)^2}{2}. \quad (4)$$

After differentiating equation (2) first by generalized coordinates, and then by time, and equations (3)–(4) by generalized coordinates, after substituting into equation (1), we obtain a system of differential equations of motion of the masses of the model of the steering control drive with an electromechanical amplifier in such form:

$$\begin{cases} J_1 \ddot{\varphi}_1 = T_k - c_1(\varphi_1 - \varphi_2) - \beta_1(\dot{\varphi}_1 - \dot{\varphi}_2); \\ J_2 \ddot{\varphi}_2 = c_1(\varphi_1 - \varphi_2) + \beta_1(\dot{\varphi}_1 - \dot{\varphi}_2) - c_3 i_p^2 (\varphi_2 - \varphi_4 / i_p) - \beta_3 i_p^2 (\dot{\varphi}_2 - \dot{\varphi}_4 / i_p) - \\ - c_2(\varphi_2 - \varphi_3) - \beta_2(\dot{\varphi}_2 - \dot{\varphi}_3); \\ J_3 \ddot{\varphi}_3 = c_3(\varphi_2 - \varphi_3) + \beta_3(\dot{\varphi}_2 - \dot{\varphi}_3) - T_O; \\ J_4 \ddot{\varphi}_4 = c_3(i_p \varphi_2 - \varphi_4) + \beta_3(i_p \dot{\varphi}_2 - \dot{\varphi}_4) + T_e. \end{cases} \quad (5)$$

The dependence of the wheel turning resistance moment on the angle of its rotation in the horizontal plane, reduced to the axis of the steering shaft, is presented in the form:

$$T_O = \begin{cases} \frac{1}{i_p} c_\omega \theta, & \theta \leq 5^\circ; \\ \frac{1}{i_p} \left[M_{\varphi \max} - (M_{\varphi \max} - c_\omega \theta) \left(\frac{\theta_B - \theta}{\theta_B - \theta_A} \right)^2 \right], & 5 < \theta \leq 13^\circ. \end{cases} \quad (6)$$

where θ – turning angle of the controlled wheel of the electric bus; $M_{\varphi \max}$ – the maximum moment of wheel rotation resistance due to tire adhesion to the road surface; θ_B – maximum turning angle of the wheel, which corresponds to the area with the maximum grip; θ_A – maximum turning angle of the wheel corresponding to the linear section.

The limiting moment of resistance of the tire to the road surface will be determined by the formula [10]:

$$M_{\varphi \max} = \frac{G_k \cdot \varphi}{16ab} \left[\begin{aligned} & (a+2y)(b+2l_0) \sqrt{(a+2y)^2 + (b+2l_0)^2} + \\ & + (a-2y)(b+2l_0) \sqrt{(a-2y)^2 + (b+2l_0)^2} + \\ & + (a+2y)(b-2l_0) \sqrt{(a+2y)^2 + (b-2l_0)^2} + \\ & + (a-2y)(b-2l_0) \sqrt{(a-2y)^2 + (b-2l_0)^2}, \end{aligned} \right] \quad (7)$$

where a, b – the sides of the reduced equal-sized rectangle of the contact impression of the tire with the support surface; y – stabilization arm; l_0 – rolling shoulder.

The rolling shoulder and stabilization shoulder are calculated according to the formulas [10]:

$$l_0 = l_c - r_k \operatorname{tg}(\alpha_{sh} + \gamma_{sh0}); \quad (8)$$

$$y = r_k \operatorname{tg} \beta_{sh}, \quad (9)$$

where l_c – length of the trunnion; r_k – radius of the controlled wheel; α_{sh} – angle of transverse inclination of the pin; γ_{sh0} – camber angle of the controlled wheel; β_{sh} – angle of the longitudinal inclination of the pin.

The system of equations (5)–(9) is a mathematical model of the steering wheel drive of an electric bus with an electromechanical amplifier, which describes the oscillatory processes in the drive during the rotation of the steered wheels of the electric bus.

Simulation model of electric bus steering wheel drive with electromechanical amplifier. Based on the developed mathematical model, a simulation model of the steering wheel drive of an electric bus with an electromechanical amplifier was built in the MathLab Simulink environment.

For the convenience of building a simulation model, we present the system of differential equations (5) in a form convenient for integration:

$$\begin{cases} \ddot{\varphi}_1 = \frac{1}{J_1} [T_k - c_1(\varphi_1 - \varphi_2) - \beta_1(\dot{\varphi}_1 - \dot{\varphi}_2)]; \\ \ddot{\varphi}_2 = \frac{1}{J_2} \left[c_1(\varphi_1 - \varphi_2) + \beta_1(\dot{\varphi}_1 - \dot{\varphi}_2) - c_3 i_p^2 (\varphi_2 - \varphi_4 / i_p) - \beta_3 i_p^2 (\dot{\varphi}_2 - \dot{\varphi}_4 / i_p) - \right. \\ \left. - c_2(\varphi_2 - \varphi_3) - \beta_2(\dot{\varphi}_2 - \dot{\varphi}_3); \right. \\ \ddot{\varphi}_3 = \frac{1}{J_3} [c_3(\varphi_2 - \varphi_3) + \beta_3(\dot{\varphi}_2 - \dot{\varphi}_3) - T_O]; \\ \ddot{\varphi}_4 = \frac{1}{J_4} [c_3(i_p \varphi_2 - \varphi_4) + \beta_3(i_p \dot{\varphi}_2 - \dot{\varphi}_4) + T_e]. \end{cases} \quad (10)$$

We present the simulation model of an electric motor in the MatLab Simulink environment as shown in Fig. 3.

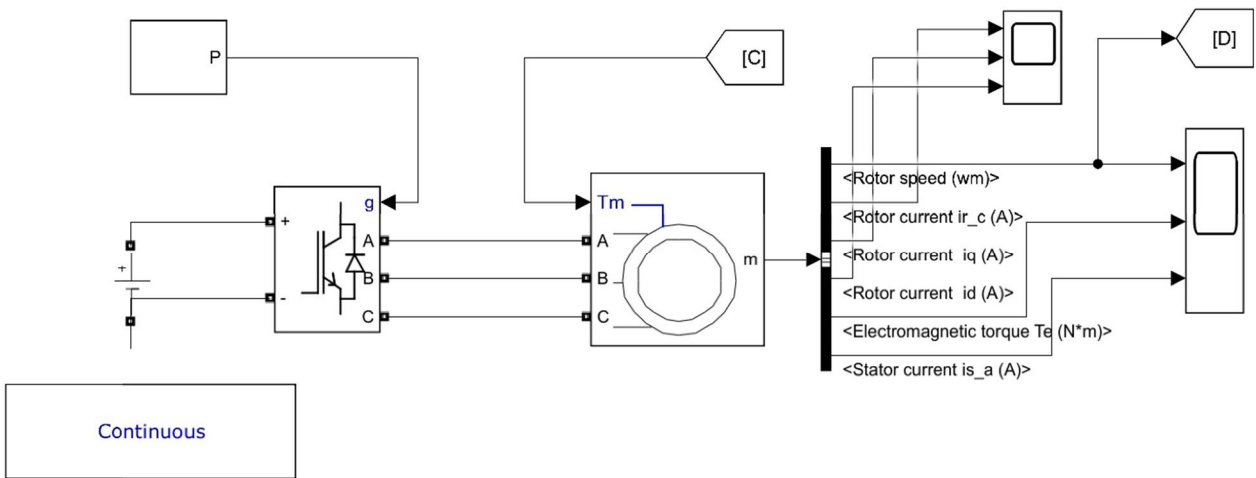

Fig. 3. Model of an asynchronous electric motor

We will create a simulation model of the mechanical part of the drive of the steered wheels of the electric bus in the form shown in Fig. 4.

By combining the simulation models of the mechanical part of the steering control drive and the electric motor, we will get a simulation model of the drive of the steered wheels of an electric bus with an electromechanical amplifier.

Oscillatory phenomena in the steering drive of an electric bus with an electromechanical amplifier.

The study of oscillatory phenomena in the drive of the driven wheels of the Electron E19101 electric bus was carried out using the following initial data: torque on the steering wheel $T_k = 20$ N·m; parameters of the electric motor: 100 HR, 575 V, 60 Hz, 1780 rpm; the length of the trunnion $l_c = 0.3$ m, the radius of the controlled wheel $r_k = 0.478$ m, the angle of transverse inclination of the pivot $\alpha_{sh} = 4^0$, the angle of camber of the controlled wheel $\gamma_{sh0} = 1^0$, the angle of longitudinal inclination of the pivot $\beta_{sh} = 2^0 30'$. The characteristics of the steering exle of the Electron E19101 electric bus are given in the Table. 1.

Table 1

Parameters of the controlled bridge RL 82 EC

Bridge type	Maximum axle load, N	Angles of rotation of steered wheels (inside/outside)	Tire size	Weight of the bridge, N
RL 82 EC	82000	max 56/46	275/70 R22.5	4820

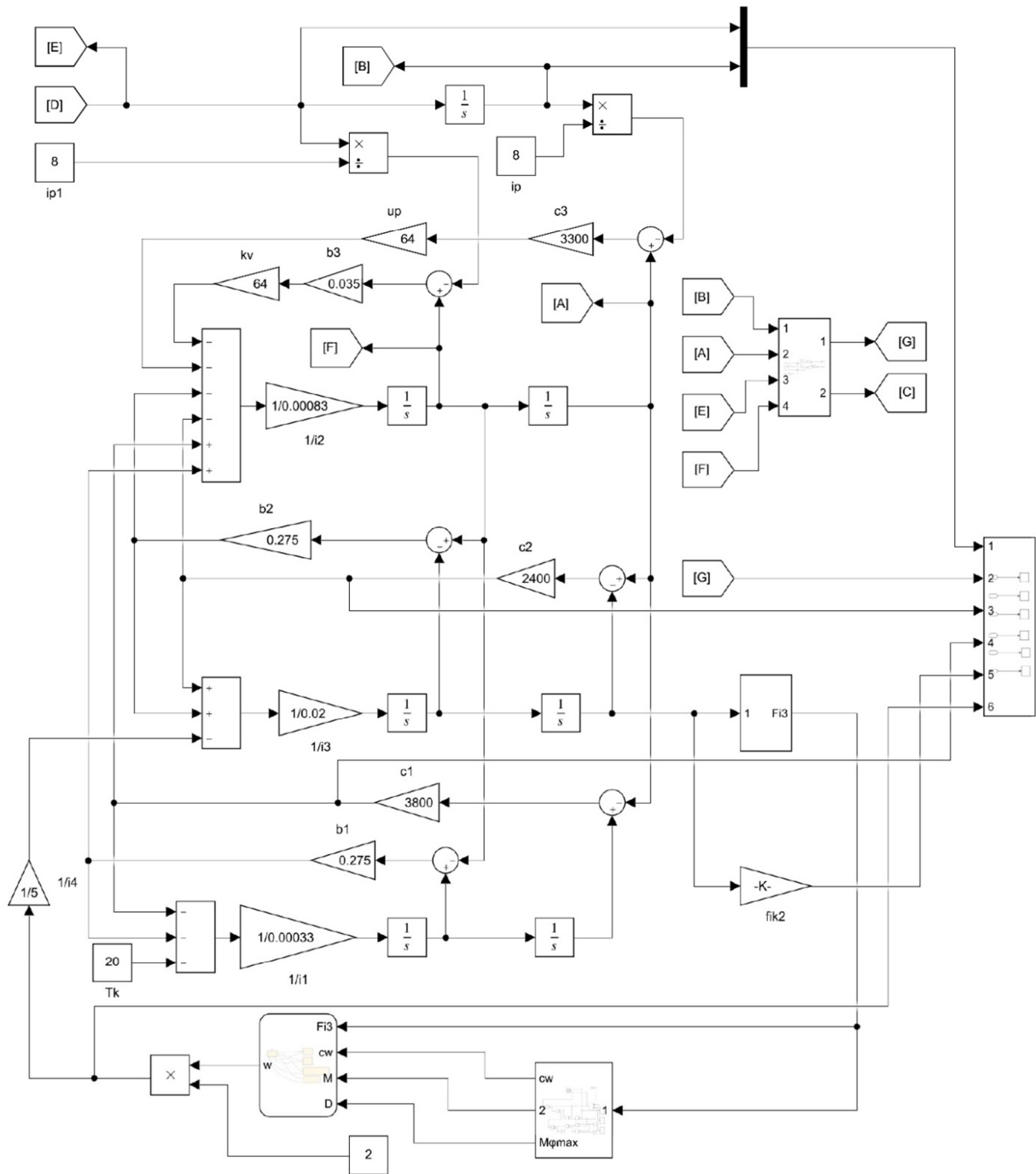

Fig. 4. Simulation model of the mechanical part of the drive of the steered wheels of the electric bus

The results of simulating oscillatory processes in the drive links of the steering mechanism of the Electron E19101 electric bus are shown in Fig. 5–11. In Fig. 5–9, the graphs shown are obtained with the total value of the gear ratio of the steering mechanism $i_s = 48$ with the distribution into gear ratios of the reducer $i_r = 12$ and the steering rack $i_k = 4$. Fig. 10 shows a graph of the change in the elastic torque T_2 in the driving part of the steering shaft as a function of time at the total value of the gear ratio of the steering mechanism $i_s = 48$ with the distribution into the gear ratios of the reducer $i_r = 8$ and the steering rack $i_k = 6$, and Fig. 11 is a graph of the change of the elastic torque T_2 in the driving part of the steering shaft as a function of time at the total value of the gear ratio of the steering mechanism $i_s = 40$ with the distribution into the gear ratios of the reducer $i_r = 8$ and the steering rack $i_k = 5$.

moment of resistance to the rotation of the driven wheels of the electric bus at the initial moment (up to 0.88 s) increases smoothly due to the elastic deformation of the tires within the angle of turning up to 5° . Later, the tread breaks down relative to the road surface, which leads to slight fluctuations in the moment of resistance rotation of the steered wheels up to an angle of 15° . It lasts from 0.88 s to 1.24 s, after which the resistance moment stabilizes at the level of 9585 N·m.

Similar oscillating phenomena occur in other links of the power steering drive. Thus, the value of the elastic torque T_2 in the driven part of the steering shaft (Fig. 6) increases to 2413 N·m, and in the shaft from the electric motor to the driven gear wheel of the gearbox (Fig. 7) – to 203 N·m. At the same time, the angle of rotation of the steered wheels is 22° .

The electromagnetic torque of the electric motor at the initial moment (Fig. 8) has a pronounced oscillatory character and varies within $+80\dots-50$ N·m, and after 1 s, it stabilizes and does not exceed 25 N·m. At the same time, the rotation frequency of the rotor of the electric motor reaches 80 rpm.

The stator current (Fig. 8) and the currents in the rotor windings (Fig. 9) do not exceed 240 A, which is quite acceptable for such a motor.

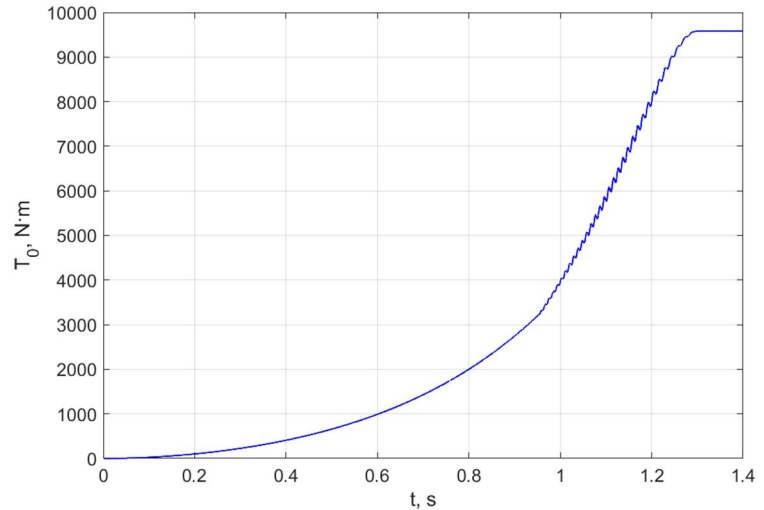

Fig. 5. Dependence of the turning resistance moment of the steered wheels on time

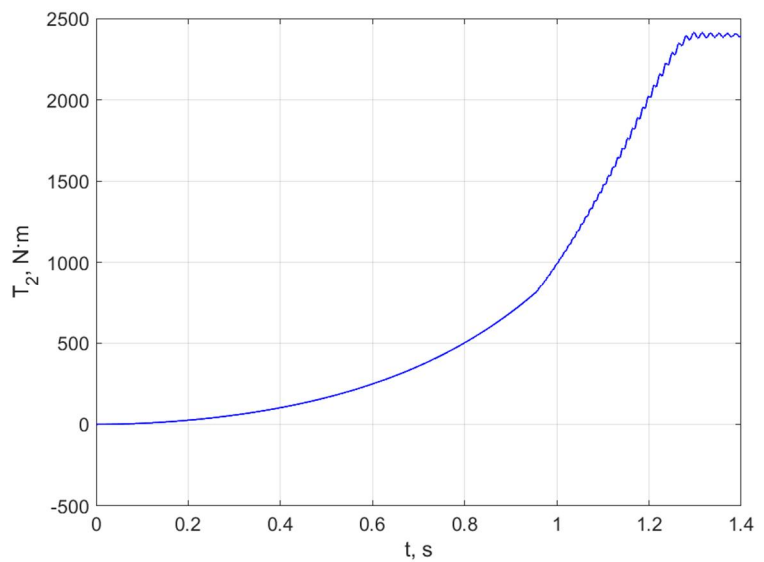

Fig. 6. Time dependence of the elastic torque T_2 in the driven part of the steering shaft

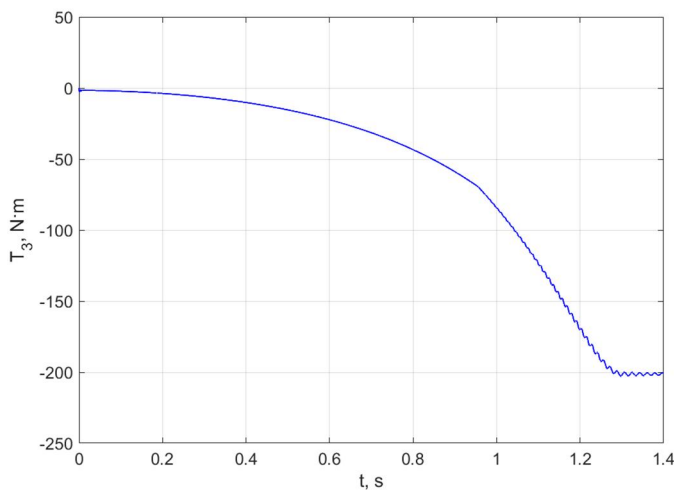

Fig. 7. Dependence of the elastic torque T_3 in the shaft from the electric motor to the driven gear wheel of the gearbox on time

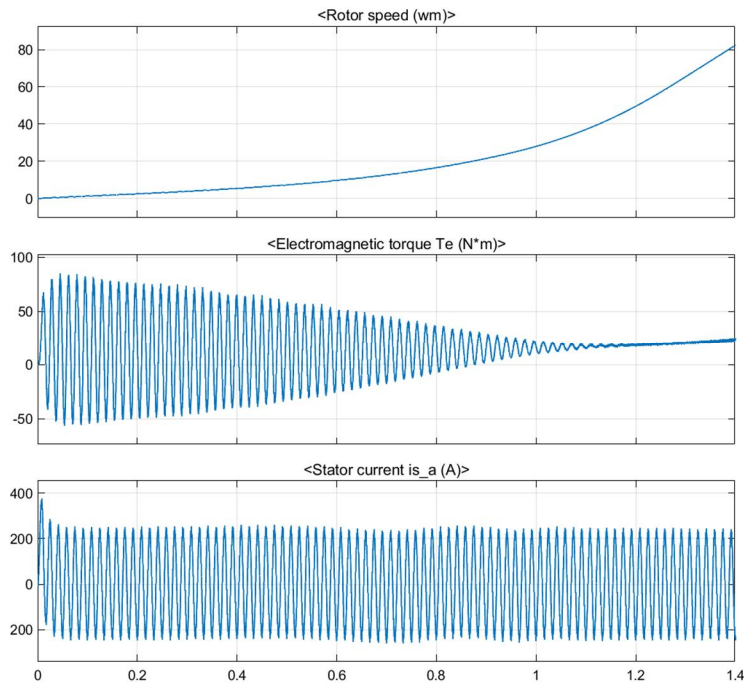

Fig. 8. Dependence of the rotation frequency of the electric motor rotor, the electromagnetic moment and the stator current on time

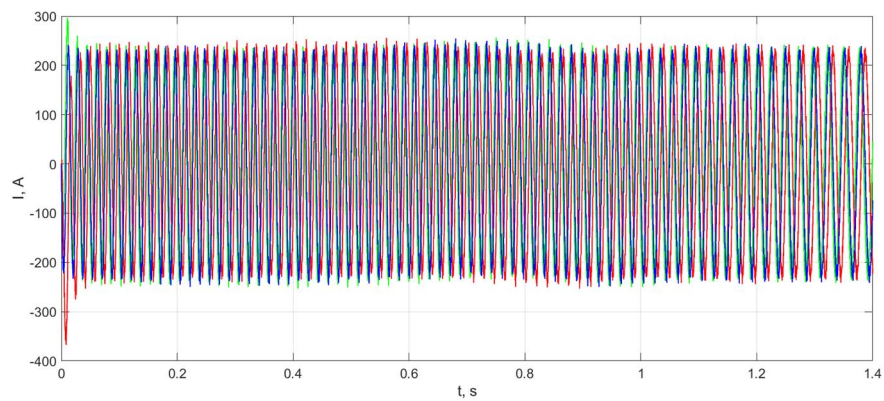

Fig. 9. Dependence of the current in the rotor windings of the electric motor on time

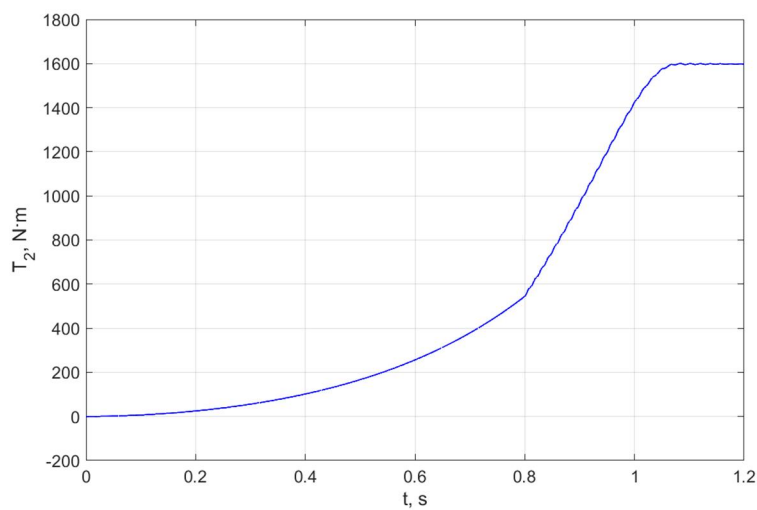
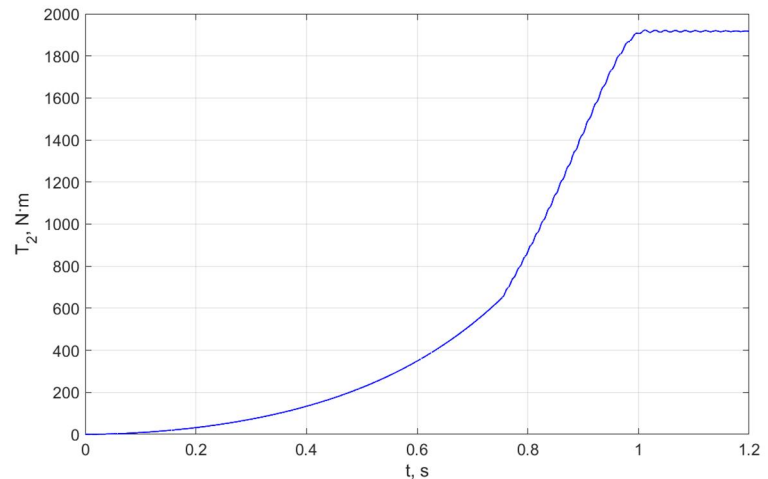

Fig. 10. Dependence of the elastic torque T_2 in the driven part of the steering shaft on time at $i_r=8$, $i_k=6$

A change in the total gear ratio of the steering mechanism and its breakdown into components (gear ratio of the gearbox and steering rack) has an insignificant effect on the duration of the steering wheel

rotation (from 1.4 s to 1.2 and up to 1.05 s when the total gear ratio of the steering mechanism is changed from 48 to 40). Reducing the total gear ratio of the steering mechanism increases the angle of rotation of the steered wheels from 220 at $i_s = 48$ to 330 – at $i_s = 40$. The change and distribution of gear ratios of the steering mechanism have a more significant effect on the magnitude of the elastic torque in the drive links (Fig. 10, Fig. 11).

Fig. 11. Dependence of the elastic torque T_2 in the driven part of the steering shaft on time at $i_r=8$, $i_k=5$



So, as a result of the conducted simulation studies, it can be concluded that the power characteristics of the electromechanical steering amplifier with the selected parameters and the electric motor can ensure the control of the wheels of the Electron E19101 electric bus following the established requirements. Dynamic loads in the drive links are not significant from the point of view of calculating their strength.

In further research, it is advisable to consider the issue of energy consumption by the drive of the steered wheels and to evaluate the energy efficiency of using electromechanical power steering in electric buses.

7. CONCLUSIONS AND FUTURE RESEARCH PERSPECTIVES

1. A dynamic model of the drive for turning the controlled wheels of the electric bus was built on the spot, taking into account the design features of the electromechanical steering amplifier and the design of the controlled bridge of the Electron 19101 electric bus.
2. Based on the dynamic model of the drive for turning the controlled wheels of an electric bus with an electromechanical steering amplifier, a mathematical model of the drive and a stimulation model were developed in the MathLab Simulink environment for the study of oscillatory processes in the drive links when the wheels turn on a horizontal plane.
3. The nature of changes in the elastic torques in the steering drive links of an electric bus with an electromechanical steering amplifier, the frequency of rotation of the rotor of the electric motor, the current strength in the windings of the rotor and stator of the electric motor, the rotation angle of the steered wheels over time was studied.
4. It was found that the change in the moment of resistance to the rotation of the steered wheels increases smoothly, and the load on the drive links of the electromechanical power steering depends on the total gear ratio of the drive and its distribution between the gearbox and the steering rack. A decrease in the total transmission ratio of the drive leads to an increase in the speed of rotation of the driven wheels and an increase in elastic moments in the drive links.
5. Transient processes in the electric part of the drive correspond to the characteristics of such electric motors by the nature of the change and do not exceed the permissible values in terms of magnitude.

6. It was established that the power characteristics of the electromechanical steering amplifier with the selected parameters and the electric motor can ensure the control of the wheels of the Electron E19101 electric bus following the established requirements.

References

1. Tambade, S. S., Bachhav, L., Gomase, S. C. S., & Holkar, S. (2020). To Drive The Vehicle Using Electromechanical Actuator. *International Journal of Scientific and Research Publications*, 10(9), 926–929. doi: 10.29322/IJSRP.10.09.2020.p105113 (in English).
2. Skurikhin, V., Soroka, K., & Aharkov, I. (2020). Matematychni modeliuvannia elektropidsylyuvacha kerma transportnoho zasobu z cherviachnoiu peredacheiu [Mathematical modeling of the electric power steering system of a vehicle with a worm drive]. *Mizhnarodnyi zhurnal "Svitlotekhnika ta elektroenerhetyka". [Lighting Engineering & Power Engineering]*, 3(59), 101–107. doi: 10.33042/2079-424X-2020-3-59-101-107 (in Ukrainian).
3. Irmer, M., Henrichfreise, H. (2020). Design of a robust LQG Compensator for an Electric Power Steering. *IFAC-PapersOnLine*, 53(2), 6624–6630. doi: 10.1016/j.ifacol.2020.12.082 (in English).
4. Kuranowski, A. (2019). Electrical power steering—modelling and bench testing. *Technical Transactions*, 116(8), 143–158. doi: 10.4467/2353737XCT.19.085.10864 (in English).
5. Wang, J., He, Y., & Yu, H. (2022). Control strategy of electric power steering system based on super-twisting algorithm. In *6th International Workshop on Advanced Algorithms and Control Engineering (IWAACE 2022)* (pp. 101–107). SPIE. doi: 10.1117/12.2652854 (in English).
6. Irmer, M., Degen, R., Nüßgen, A., Thomas, K., Henrichfreise, H., & Ruschitzka, M. (2023). Development and Analysis of a Detail Model for Steer-by-Wire Systems. *IEEE Access*, 11, 7229–7236. doi: 10.1109/ACCESS.2023.3238107 (in English).
7. Brykczynski, M (2019). A model based analysis of dynamics of a single pinion electric power steering system. *Designing, researches and exploitation*, 1(4), 39–46. (in English).
8. Loyola, J., Lee, K., & Margolis, D. (2021). Modeling Non-Backdriving Behavior in an Electromechanical Steering Actuator Using Bond Graphs. In *2021 International Conference on Bond Graph Modeling and Simulation, ICBGM 2021* (pp. 149–160). (in English).
9. Yamamoto, K. (2017). *Control of electromechanical systems, application on electric power steering systems*. Doctor's thesis. Université Grenoble Alpes (in English).
10. Aharkov, I. (2020). Vyznachennia mekhanichnykh parametriv elektrychnoho pidsylyuvacha kerma u systemi rulovoho keruvannia troleibusu [Determination of mechanical parameters of electric power steering of the trolleybus steering system]. *Transportni systemy i tekhnologii. [Transport systems and technologies]*, 35, 52–59. doi: 10.32703/2617-9040-2020-35-6 (in Ukrainian).
11. Elektropidsylyuvach kerma [Electric power steering]. <http://dak.dn.ua/2021/12/16/elektropidsilyuvach-kerma-eur-yak-pratsyuuye-vlashtovano-osnovni-vidi/>. (in Ukrainian).

Received 12.09.2023; Accepted in revised form 06.11.2023.

ВПЛИВ ОПОРУ ПОВОРОТУ КОЛЕСА НА КОЛИВАЛЬНІ ЯВИЩА У ПРИВОДІ КЕРМОВОГО КЕРУВАННЯ ЕЛЕКТРОБУСА З ЕЛЕКТРОМЕХАНІЧНИМ ПІДСИЛЮВАЧЕМ

Анотація. Системи кермового керування з електромеханічним підсилювачем (ЕМП) є сучасним конструктивним рішенням, порівняно з гідравлічними та електрогідравлічними системами кермового керування. У приводах кермового керування сучасних тролейбусів та електробусів застосовують гідравлічні підсилювачі керма. Якщо у тролейбусах для приведення в рух гідравлічного насоса використовується електродвигун, що живиться від електромережі, то в електробусах джерелом електричного живлення є акумуляторні батареї. Витрата енергії на забезпечення роботи гідравлічного підсилювача керма зменшує пробіг електробуса між заряджаннями акумуляторних батарей. Тому здійснення

дослідження й обґрунтування можливості застосування ЕМП в електробусах є актуальним і має важливе практичне значення.

З урахуванням конструктивних особливостей електромеханічного підсилювача керма і конструкції керованого моста електробуса Електрон 19101 побудована динамічна модель приводу повороту керованих коліс електробуса на місці. На основі динамічної моделі приводу повороту керованих коліс електробуса з електромеханічним підсилювачем керма розроблені математична модель приводу і стимуляційна модель у середовищі MathLab Simulink для дослідження коливальних процесів у ланках приводу під час повороту коліс на горизонтальній площині. Досліджено зміни пружних крутних моментів у ланках приводу кермового керування електробуса з електромеханічним підсилювачем керма, частоти обертання ротора електромотора, сили струму в обмотках ротора і статора електромотора, кута повороту керованих коліс від часу. Встановлено, що зміна моменту опору повороту керованих коліс зростає плавно, а навантаження на ланки приводу електромеханічного підсилювача керма залежить від загального передатного числа приводу і його розподілу між редуктором і кермовою рейкою. Зменшення загального передатного числа приводу призводить до збільшення швидкості повороту керованих коліс і зростання пружних моментів у ланках приводу. Перехідні процеси в електричній частині приводу за характером зміни відповідають характеристикам для таких електромоторів, а за величиною не перевищують допустимі значення. Встановлено, що силові характеристики електромеханічного підсилювача керма з вибраними параметрами і електромотором можуть забезпечити керування колесами електробуса відповідно до встановлених вимог.

Ключові слова: електромеханічний підсилювач керма; електробус; симуляційна модель; кермове керування; динамічна модель; електромотор.