

DC MOTOR CONTROL SYSTEM WITH OPTIMIZATION OF THE TRANSIENT DURATION

Volodymyr Samoty, Dr.Sc., Professor
e-mail: volodymyr.v.samoty@lpnu.ua

Roman Horun, student

Lviv Polytechnic National University, Ukraine

<https://doi.org/10.23939/istcmtm2023.04>.

Abstract. The synthesis of the structure of the automatic control system of direct current motors is carried out, and the methodology of the study of the duration of the transient process during the control of the direct current motor is presented. A study of the influence of the regulator parameters on the duration of the transition process was carried out, which allowed to choose the optimal ones for the criterion of the minimum duration of the transition process

Key words: Control system, electric drives, starting torque, control method, magnetic flux, motor inertia.

1. Introduction

The widespread use of direct current motors (DCMs) is due to their high starting torque, maximum power/mass ratio, and low nonlinearity of mechanical and control characteristics [1]. The main areas of application of DC motors are electric drives in industry, transportation, cranes, rolling mills, etc. The DC motor control system is a part of the electric drive, devices, and any technical means that have an electric drive. The main purpose of the control is to manage complex technological processes that require precise regulation of motor speed and torque.

2. Disadvantages

One of the main problems in the control of the DCM is the duration of the transient mode that occurs when the engine mode changes. This mode is characterized by a sharp change in speed, which leads to malfunctions in the control system and damage to the mechanisms of the engine. Optimizing the duration of the transient mode is a task that requires the development of control algorithms and the use of the latest approaches to the development of control systems. Such methods can improve the quality of motor control, reduce its weight and size, and reduce energy consumption.

3. Goal

The article aims to develop and study a DC motor control system with minimizes the duration of the transient mode by determining its parameters and operating peculiarities.

4. Direct Current Motors' Control Methods

The main tasks of the study include establishing the optimal parameters of the controller and the control law, which will allow for achieving the minimum transient time and ensuring stable and accurate operation of the automatic control system. In addition, the goal is to determine the impact of different types of regulators (P, PI,

PI, PID) on the dynamics of the DC motors and to select the most efficient type of regulator for a particular system.

A simplified mathematical model that considers non-linear effects and aspects of the actual operation of the DC motor. Limited optimization of only one parameter – the type of controller, without considering other possible system parameters. Analysis of the impact of noise and failures on the operation of the automatic control system is absent.

The control methods of the DC motors are used to smoothly and accurately control the speed and torque of these motors. One of the control methods is to change the current in the rotor circuit utilizing an additional electrical resistance [1]. This method allows you to adjust the motor speed smoothly and within a wide range. Another method is to change the supply voltage, which also affects the motor speed [2]. The magnetic flux in the current DCM can be changed by a rheostat. This method makes it possible to adjust the motor speed and torque.

The application of control methods makes it possible to achieve smooth and precise control of these motors in various fields, including industry and automation.

Pulse width modulation (PWM) is a popular method of controlling the DC motors, effective controlling of the rotor frequency and torque [3]. This method is based on changing the time duration of the supply voltage pulses supplied to the motor to control its operating mode.

PWM utilizes a high-voltage power supply and effectively control the voltage supplied to the motor. By varying the pulse width, the average voltage and current supplied to the motor can be controlled. This method control the speed and torque of the motor not changing the source voltage itself.

There are several different methods of PWM, the main ones include:

1. Pulsating PWM [4] – the width of the pulse changes, and the time between pulses remains constant. This allows you to adjust the average value of the motor supply voltage.

2. Frequency PWM – the pulse frequency is controlled and the pulse width remains constant. Changing the frequency affects the average value of the supply voltage.

3. Phase PWM – the phase of the pulses changes relative to the beginning of the time cycle, and their pulse width and frequency remain constant.

The use of PWM allows for achieving high efficiency and accuracy of the DCM control, reducing power losses and increasing the accuracy of response to control commands.

The duration of the transient mode in the SPC depends on the following factors:

- Motor inertia: The greater the motor inertia, the longer it takes for the speed to change during transient conditions.

- Load torque: Higher torque requires more time for the motor to reach steady state operation.

- Collector resistance: The resistance of the collector winding (including the brushes) affects the time it takes to reach a steady state value of the winding current during transient operation.

- Rotor winding inductance: A higher inductance results in a longer transient.

- EMF flux ratio: The inverse electromotive force coefficient of a motor determines the rate of change in motor speed according to the change in applied voltage. A higher back EMF ratio results in a shorter transient duration.

These factors can interact with each other, and the actual transient duration will depend on the specific motor model and operating conditions.

5. DCM control system research

The automatic control system shown in Fig. 1 is a set of tools and algorithms designed to automatically control the operation of DC motor to maintain the set value of the rotor speed. The main purpose of automatic control systems is to ensure the stability, accuracy, and speed of the system's response to changes in external conditions or the internal parameters of the object. This is achieved by continuously comparing the measured rotor frequency values with the set values and issuing control actions to the DC motors depending on the difference between them.

The main components of the automatic control system are:

1. The object of regulation is the DC motor.
2. Rotor speed sensor.
3. Regulator – a device that calculates the difference between the set frequency value and its current value, determines the controlling influence, and transmits it to the executive bodies.
4. Executive bodies – motor driver: Exerts a controlling influence on the DCM.
5. Feedback – allows you to monitor the current state of the object and adjust the control influences according to the actual results.

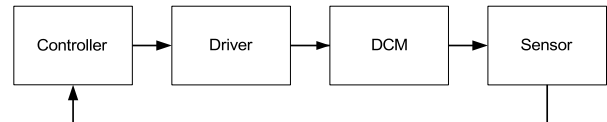

Fig. 1. Structure of DCM control system.

The type of DCM is determined by the target system and can usually be selected from a limited set. The purpose and function of the "driver" in a DCM system is to provide the appropriate voltage and current to the motor to achieve the specified operating conditions.

The main functions of the driver include:

1. Signal conversion – the driver receives the control signal from the controller and converts it into the appropriate voltage and current signals to be supplied to the DCM.

2. Controlling the supply current to the DCM to perform the control task.

3. Motor protection – can include overload, short circuit, overheating, etc. of the protection circuits and helps prevent possible damage to the DCM during the operation, or other abnormalities in operation.

4. Controlling the supply voltage of the DCM with changes in speed and torque. It may be necessary to adjust the supply voltage of the motor.

In some cases, the motor driver may be integrated into the motor itself, while in others it may be a separate device. This depends on the specific requirements and characteristics of the automatic control system and the object to be controlled.

Integrated bridge drivers, such as those based on L293 chips, or modules based on them, are popular for controlling low-power motors. The analysis of the speed sensors of the IBC is important for the effective control and management of such motors. The key aspects that are considered while analyzing the speed sensors of the rotors of the DCM are:

1. Measurement accuracy is critical to ensure stable and accurate regulation of the system.
2. Response time which characterizes the speed of reaction to changes in rotational speed.
3. Resolution which characterizes the minimum value of the rotational speed change that can be tracked.
4. Measuring range which characterizes the width of the range of possible rotational speeds that may occur during system operation.
5. Noise and fault tolerance which characterizes the reliability of the system.
6. Communication interface which characterizes compatibility with other system components.

It is important to select the appropriate sensors for the system of controlling the speed of the DCM, considering the specific requirements of the system and technical capabilities.

The structure of the PSC controller can be quite complex and varied depending on the specific requirements and functions of the automatic control system. However, the main components that may be included in the structure of a DCM controller include:

1. The controller – the central unit of the controller that receives input signals, usually from sensors, and compares them to set points. Depending on the difference between the input signals and the set points, the controller generates control signals for the next stages.

2. Pulse width modulator (PWM): Pulse width modulation can be used to control the speed and supply voltage of the DCM. This unit converts the controller's analog signal into a pulsating variable pulse width signal that controls the voltage applied to the DCM.

3. Control Parameter Control Unit, a module that provides real-time tuning of control parameters to ensure optimum performance and stability.

4. Measurement system – includes measuring transducer circuits that provide input of measurement information, primarily from the rotor frequency sensor or other sensors.

5. Adaptation and optimization unit – a part of the system that allows the system to independently adjust the control parameters depending on changing operating conditions.

6. Methodology for studying the duration of the transition process

The methodology for measuring the duration of transients in the DCM can be performed using an oscilloscope and includes the following steps:

– Preparatory: Before the measurement, it is necessary to prepare the equipment, in particular, the oscilloscope, and the measuring device, and to connect the sensors to collect the relevant data.

– Setting up the equipment: Setting the parameters of the oscilloscope, and other components of the control system, such as time scale, vertical scale, acquisition mode, and others, to ensure that transient signals are properly displayed.

– Turn on the motor: Starts a DC motor and measures the current and voltage at the motor input.

– Transient time measurement: During startup, or a change in operating mode, the DUT observes changes in current and voltage. The oscilloscope records these changes over time, allowing the duration of the transients to be determined.

– Data analysis: The data obtained is analyzed to determine the duration of the transients, which can be

defined, for example, by the time it takes for the signal to reach a certain percentage of its steady-state value.

– Processing of results: The results of the analysis are used to determine the characteristics of the transients, such as time to set, time to burst, and other parameters.

This methodology helps to measure and analyze the duration of transients in DC motors, aiming the determination of their efficiency and compliance with technical standards.

Reducing transient duration in DC motors can be achieved through several methods and measures applying:

– Current control: The use of special control algorithms to smoothly adjust the current when starting and stopping the motor can help avoid sudden changes and reduce transients.

– Filters: Installing filters on the power line can reduce the effects of noise and interference that can cause transients.

– Voltage regulators: Using voltage regulators helps to provide a stable input signal to the motor, which can have a positive effect on transients.

– Inertial loads: Adding inertial loads to the motor shaft can reduce the rate of change of current and help reduce transients.

– Control parameters: Selecting optimal control parameters, such as acceleration and deceleration times, can provide smoother transitions between motor operating modes.

– Regenerative braking: Then the kinetic energy can be converted back into electrical energy, which can also reduce braking transients.

– Optimization of throttle resistances: Selecting optimal values for the choke resistances can reduce the rate of change of the current and reduce transients.

In general, a combination of these methods and measures can help reduce the duration of transients in DC motors and improve their dynamics and performance.

7. Results and Discussion

The study of the parameters of the designed automatic control system can be carried out both through study and simulation [6]. A description of its settings and operating principle is presented in [7]. This simulator allows you to set a mathematical model of the control object and study the effect of controller parameters on the parameters of the automatic control system. The mathematical model of the DCM depends on its operating mode and engine parameters [8]. A linearized model of such an engine is shown in Fig. 2.

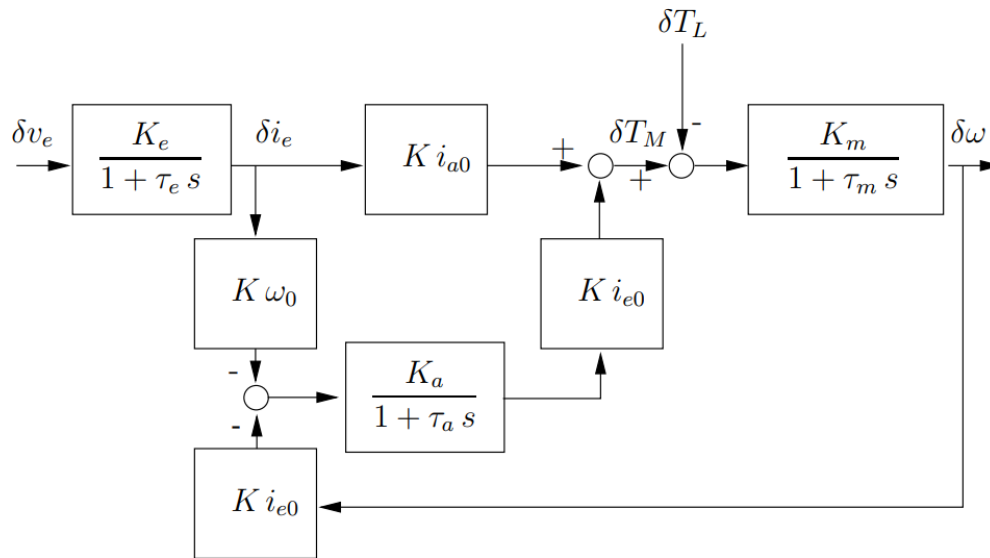

Fig.2. Linear model of DCM

The function of the rotor moment of inertia δT_M on the supply voltage δv_e and rotor speed $\delta \omega$ is described by the following relationship:

$$\delta T_M = K K_e \frac{(1 + \tau_a s) i_{a0} - K K_a i_{e0} \omega_0}{(1 + \tau_a s)(1 + \tau_e s)} \delta v_e - K_a \frac{(K i_{e0})^2}{1 + \tau_a s} \delta \omega.$$

The rotor speed dependence is described:

$$\frac{\delta \omega(s)}{\delta v_e(s)} = \frac{K_m K_a K ((1 + \tau_a s) i_{a0} - K K_a i_{e0} \omega_0)}{(1 + \tau_e s) ((1 + \tau_m s)(1 + \tau_a s) + K_m K_a (K i_{e0})^2)}$$

$$\frac{\delta \omega(s)}{\delta T_L(s)} = -K_m \frac{1 + \tau_a s}{((1 + \tau_m s)(1 + \tau_a s) + K_m K_a (K i_{e0})^2)}$$

By substituting this dependence into the field "T(dt)=" of the simulator's linearization and the corresponding coefficients of the PID controller, it is possible to study the time dependence of signals in the automatic control system. An example of this dependence is shown in Fig. 3.

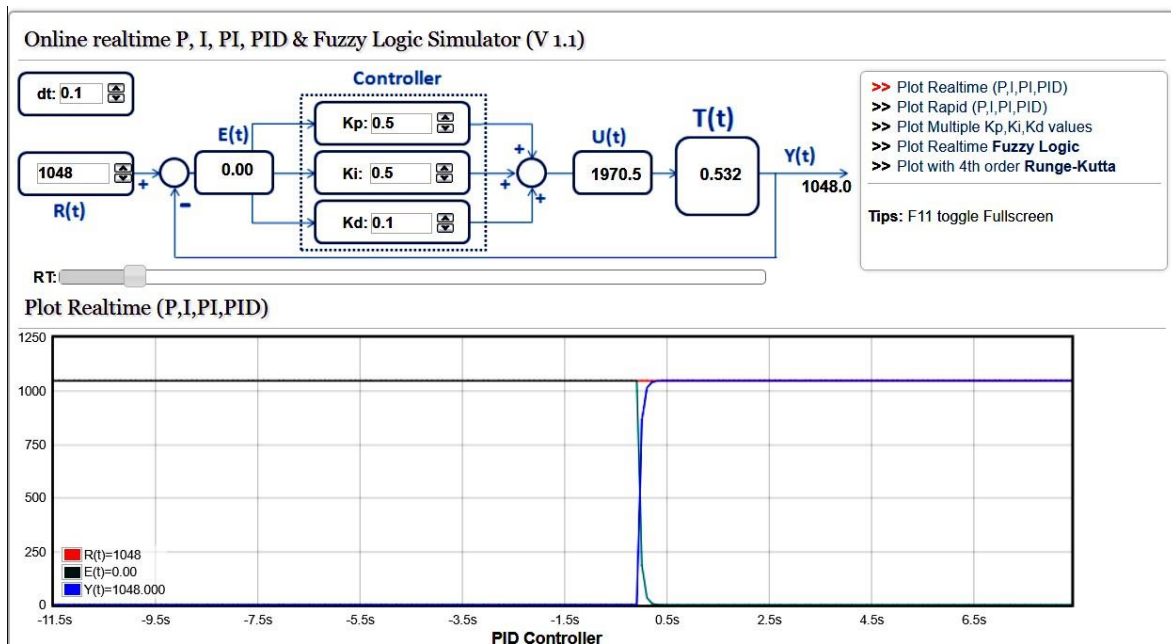

Fig. 3. Time dependencies of signals of the automatic control system of the fuel injection system

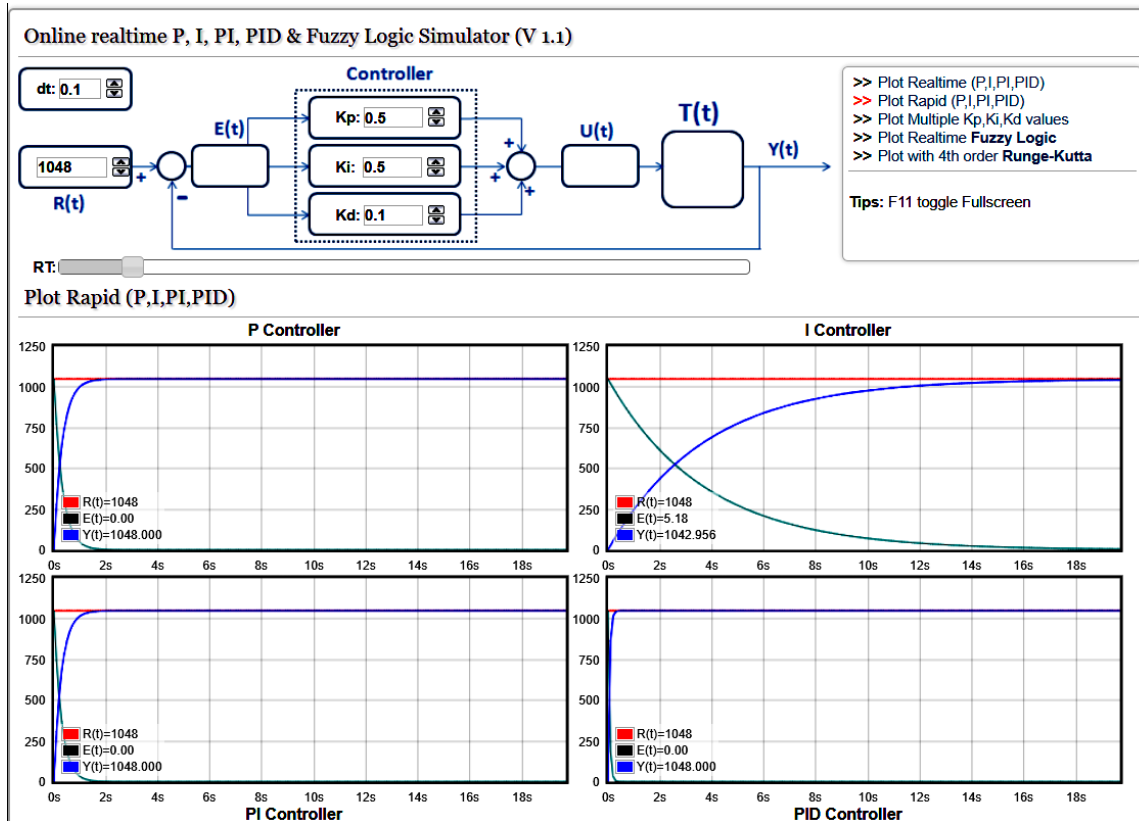

Fig.4. Comparative analysis of P, PI, I, and PID controllers

In this simulator, you can also build a P, PI, and PID controller with the specified parameters and perform their comparative analysis (Fig. 4). As you can see, the PID controller provides the shortest transient duration.

The peculiarity of this stimulator is the ability to set a set of parameters and to construct time dependencies of signals for each of the parameters and each type of controller. The dependence for the P controller is

shown in Fig. 5, for the I controller in Fig. 6, for the PI controller in Fig. 7, and for the PID controller in Fig. 8. In this way, it is possible to select the coefficients with the best controller characteristics and study their effect on the duration of the transient process. As can be seen from the diagrams, the shortest transient for the DCM is provided by the PID controller with parameters $K_r=1$, $K_i=1$, $K_d=0.1$.

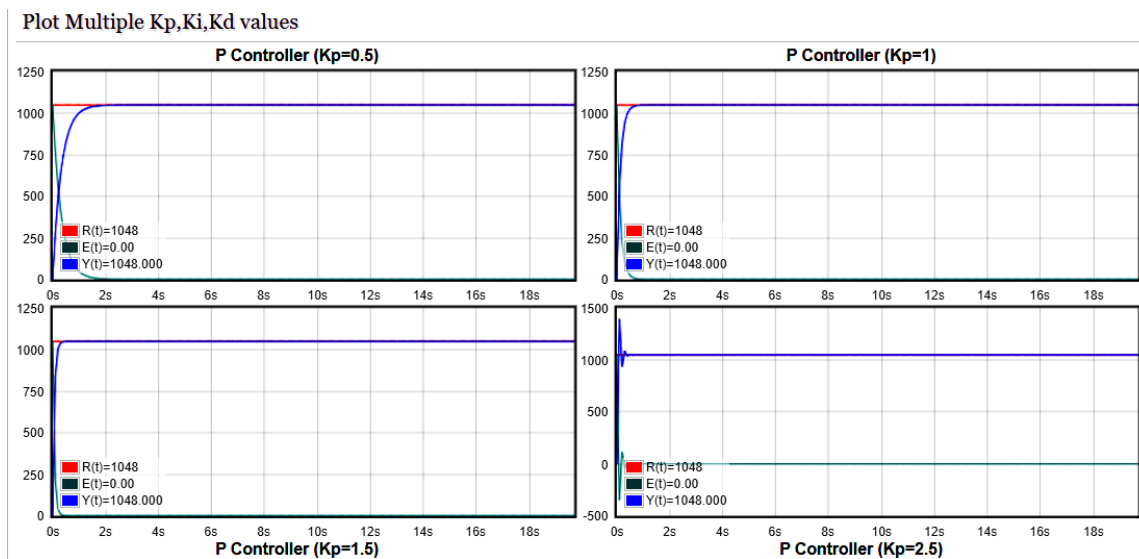

Fig. 5. Characteristics of the P controller

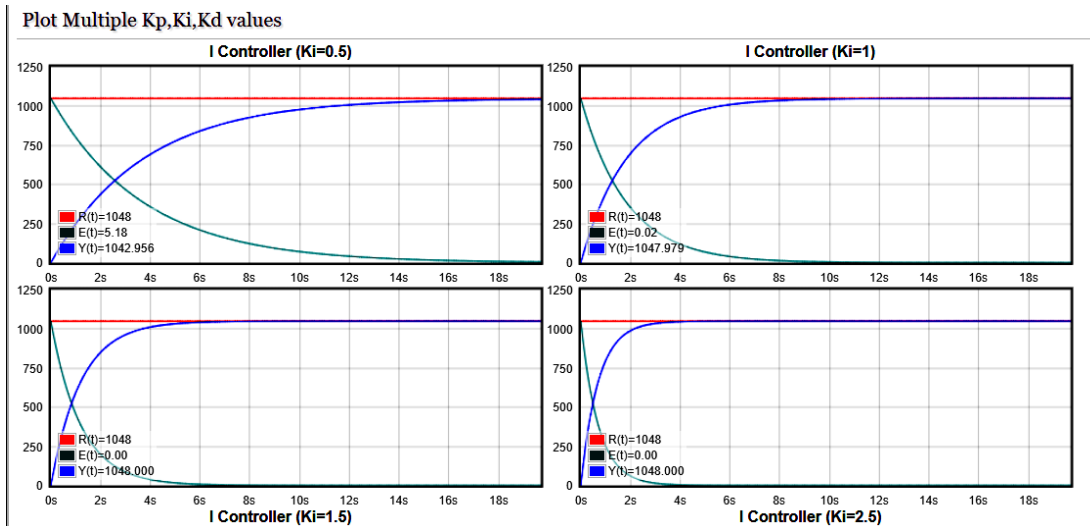

Fig.6. Characteristics of the I controller

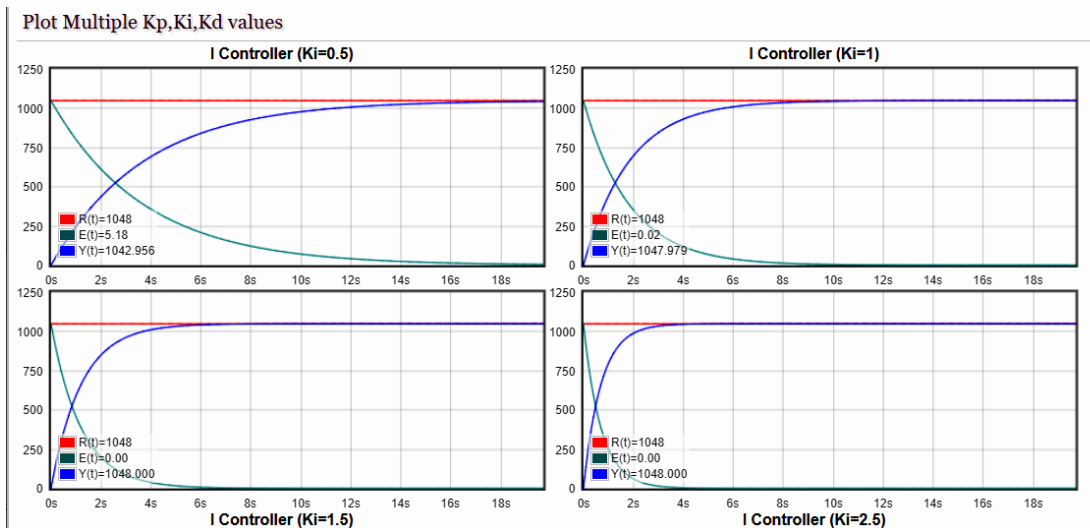

Fig. 7. Characteristics of the PI controller

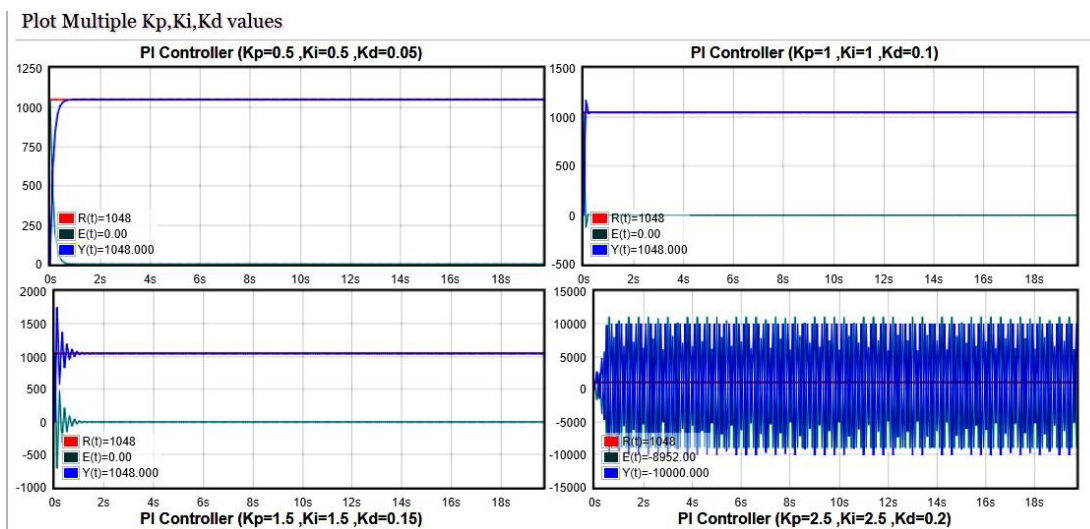

Fig. 8. Characteristics of the PID controller

8. Conclusion

The reviewed methods of controlling DC motors were studied to synthesize an optimal block diagram of the system for automatic control of the rotor speed. The carried out simulation of the control system contributed to selection of the optimal values of the controller parameters ensuring the minimal transient time.

9. Gratitude

The authors express their gratitude to the Editorial Board of Journal for their help.

10. Conflict of Interest

The authors state that there are no financial or other potential conflicts regarding this work.

References

- [1] S. Mansmann, T. Neumuth, M. H. Scholl, Multidimensional Data Modeling for Business Process Analysis, 26th Int. Conf. on Conceptual Modeling, Nov. 5-9, 2007, Auckland, New Zealand. DOI:10.1007/978-3-540-75563-0_4
- [2] M. Ruderman, , et al. "Optimal state space control of DC motor." IFAC Proceedings Volumes 41.2 (2008): 5796-5801. https://www.researchgate.net/publication/216232528_Optimal_State_Space_Control_of_DC_Motor
- [3] B. Umesh Kumar, and R. Narvey. "Speed control of DC motor using fuzzy PID controller." Advance in Electronic and Electric Engineering 3.9 (2013): 1209-1220.
- [4] Y. Kin, and J. Huang. "Development of a remote-access laboratory: a DC motor control experiment." Computers in Indu-

- [5] Saab, Samer S., and Raed Abi Kaed-Bey. "Parameter identification of a DC motor: an experimental approach." ICECS 2001. 8th IEEE International Conference on Electronics, Circuits, and Systems (Cat. No. 01EX483). Vol. 2. IEEE, 2001. <https://www.semanticscholar.org/paper/Parameter-identification-of-a-DC-motor%3A-an-approach-Saab-Kaed-Bey/9>.
- [6] S. Koyamada, Y. Shikauchi, K. Nakae, M. Koyama, S. Ishii. Deep Learning of FMRI big data: a novel approach to subject-transfer decoding. 31 Jan. 2015. <https://arxiv.org/abs/1502.00093>
- [7] H. C. Purchase, N. Andrienko, T. J. Jankun-Kelly, M. Ward. Theoretical Foundations of Information Visualization. In: Inf. Visualization: Human-Centered Issues and Perspectives, 1970, pp.46-64. DOI:10.1007/978-3-540-70956-5_3
- [8] K. Börner, C. Chen, K. Boyack. Visualizing knowledge domains. An. Rev. of Inf. Sc. & Techn., vol. 37, 2003, Medford, NJ: Information Today, Inc./Amer. Soc. for Inf. Sc. and Techn. https://www.academia.edu/2874912/Visualizing_knowledge_domains
- [9] J. Emerson, W. Green, B. Schloerke, J. Crowley, D. Cook, H. Hofmann, H. Wickham. The Generalized Pairs Plot. Journ Comp. and Graph. Statistics, vol. 22(1), 2013, pp. 79– 91. DOI: 10.1080/10618600.2012.694762
- [10] D. Andrews. Plots of high-dimensional data, Biometrics, Vol. 28, no.1, 1972, pp. 69-97. DOI:10.2307/2528964
- [11] O. Poliarus, Y. Poliakov, A. Lebedynskyi. Detection of landmarks by autonomous mobile robots using camera-based sensors in outdoor environments. IEEE Sensors Journal, vol. 21, iss.10, 2021, pp. 11443-11450 DOI:10.1109/JSEN.2020.3010883.