

## ANALYSIS OF REAL-TIME PROCESSING APPROACHES FOR LARGE DATA VOLUMES IN METERING INFRASTRUCTURE

Roman Moravskiy<sup>1</sup>, Yevheniya Levus<sup>2</sup>

Lviv Polytechnic National University, Department of Software Engineering, Lviv, Ukraine

<sup>1</sup>E-mail: roman.o.moravskiy@lpnu.ua, ORCID: 0000-0002-6695-1920

<sup>2</sup>E-mail: yevheniia.v.levus@lpnu.ua, ORCID: 0000-0001-5109-7533

© Moravskiy R., Levus Y., 2024

Smart grid systems and communication technologies, such as Advanced Metering Infrastructure (AMI), have revolutionized utility service management and monitoring. AMI leverages smart meters equipped with advanced communication capabilities, facilitating bidirectional communication between utilities and consumers. The increasing deployment of smart meters and the adoption of sub-hourly data collection requirements by utility companies highlight significant data volume growth. Thus, there is a need for efficient real-time data processing solutions as existing approaches may not meet previously established Service-Level Agreements (SLAs) concerning performance, accuracy, and scalability metrics. This research aims to comprehensively review the latest publications relevant to distributed real-time data processing methods for smart grid applications and outline problems for further research. Specifically, the study delves into the effectiveness and application of reviewed approaches in managing the constant stream of data from smart meters and IoT devices within the smart grid context. By analysing existing methodologies and advancements, this study seeks to identify challenges and opportunities in real-time data processing for smart grid infrastructures, focusing on addressing the complexities of processing, managing, and storing large volumes of real-time data. The literature review revealed two primary applications of real-time data processing: optimization of data streaming performance and data analysis. The review encompasses various studies, each presenting distinct methodologies and technologies applied to address the challenges of processing large volumes of real-time data from smart meters and IoT devices. Future research should address the challenges and limitations discovered in this study.

**Key words:** real-time distributed processing; data streaming; smart grid (SG); smart meter (SM); Advanced Metering Infrastructure (AMI).

### Introduction

In the last decade, interest in advanced energy management systems and communication technologies has risen significantly [1]. These technologies provide a pathway towards more efficient, resilient, and sustainable energy systems, benefiting both customers and utilities. Various communication protocols [2–6] have been developed to facilitate data collection from measuring devices. Comprehensive smart metering solutions were designed to enable efficient utility service management, monitoring, and control. Among these solutions, Advanced Metering Infrastructure (AMI) [7, 8] stands out as a transformative approach to managing utility, which supports all stages of the measured data life cycle, from data collection to the final delivery of energy consumption statistics to end users [9]. AMI leverages a network of smart meters [10] equipped with advanced communication capabilities and data management systems with bidirectional communication between utilities and consumers. This infrastructure features automated

meter reading in regular hourly or sub-hourly intervals and various real-time processes, including those performed near smart meters, such as real-time load monitoring and analysis [11], data compression [12] and control of energy consumption patterns. Additionally, it supports tasks executed at later stages of the general data pipeline, such as fraud detection [13], outage detection and management, dynamic pricing adjustments [14], and load forecasts [15, 16].

As urban populations grow, the demand for intelligent energy solutions rises proportionally. More and more smart meters are being installed, and their penetration rate has risen significantly. For instance, the report from 2017 [17] shows that by 2016, the number of AMI installations in the U.S. was about 70.8 million, equal to about 47 % of total electric meters and according to [18], this number grew to 199 million installations, equal to about 72 % of total electric meters installations.

As of 2017, Ukraine had an estimated 20.7 million electric meters, with approximately 18.6 million primarily in the household sector and the remaining 2.1 million deployed in the industrial and utility sectors. Automated Meter Reading (AMR) systems are mostly utilized in industrial installations. Even though smart meters are used in residential and utility services at some scale, in most cases measurements are not collected frequently, usually just a few times a month, primarily for billing purposes. According to [19], in addition to low AMR coverage, several significant factors negatively impact the state of automation of electricity metering in Ukraine:

- Smart metering systems deployed in industrial enterprises primarily monitor consumption patterns rather than facilitate settlement calculations, except for non-regulated tariff supplies.
- Incompatibility issues arise due to the development of AMR systems based on different normative requirements, particularly concerning communication protocols for system access and data exchange.
- Technical limitations such as the absence of a unified system for accurate timekeeping and measurement synchronization.

Recent studies [20] and [21] underscore the critical need for implementing a smart grid system in Ukraine, particularly in the aftermath of the partial destruction of the energy infrastructure due to the Russian bombing. Moreover, effective real-time handling of cyber threats, as highlighted in [20], is also of greatest importance. One of the pivotal advantages of a smart grid system is its capacity to enable utilities to monitor and rebalance electricity networks in real-time, which could significantly assist during periods of high peak consumption.

The necessity for real-time processing approaches in AMI stems from the increasing complexity and scale of modern energy systems. With the widespread adoption of smart meters, there's a significant uptick in real-time data processing related to energy consumption. This data holds valuable insights for utility providers, aiding them in optimizing energy distribution, detecting anomalies, and enhancing system efficiency. By deploying efficient real-time processing solutions, utilities can fully utilize AMI, leading to more resilient, sustainable, and responsive energy networks.

### **Problem statement**

The challenge addressed in this study revolves around the complex task of effectively processing, managing, and storing large volumes of real-time data within smart metering infrastructures. This complexity arises from several factors. Firstly, meter readings are collected using various communication protocols, resulting in heterogeneous data that needs unification for processing and analysis. Additionally, regulatory requirements in some regions mandate that meter readings be collected as frequently as every 15 minutes [22], exponentially increasing the data load. Furthermore, utility providers set different Service Level Agreements (SLAs), which consist of various performance metrics, including data processing efficiency, latency, throughput, availability, and reliability, suited to meet each utility's unique needs and priorities.

Achieving efficient real-time processing, akin to near-real-time with minimal delay between data acquisition and action, under these conditions necessitates addressing numerous obstacles. These include

ensuring scalability to accommodate the installation of new meters, using adaptable processing algorithms capable of handling diverse data types and potentially incorporating advanced optimization techniques to enhance system performance. Addressing these challenges requires innovative solutions tailored to the unique needs of smart metering infrastructures.

### **Purpose of the article**

This research aims to comprehensively review the latest publications that are relevant to the topic of distributed real-time data processing methods for smart grid applications. Specifically, the study delves into the effectiveness and application of reviewed approaches in managing the constant stream of data from smart meters and IoT devices within the smart grid context.

### **Analysis of the latest research and publications**

In the study [23], the authors used Apache Kafka to replace the previous batch-processing design with an event-streaming approach. This streaming platform served as the communication bridge between an independent Head-End System (HES), comprising a data collector and meter data library, and the Meter Data Management System (MDMS) application. During the experimental phase, the primary focus was evaluating the meter reading performance, particularly concerning load profile (LP) data. The experiment involved 1191 meters over seven days, each generating LP data at 15-minute intervals (totalling 96 LP data points per day). Unfortunately, the experiment had to be halted due to infrastructure availability issues. Nonetheless, the data collected within the initial 4.5 hours provided sufficient evidence to conclude that the enhancement was successful.

Real-time ETL process was explored in [24]. Apache Kafka was also chosen as the primary communication component alongside Kafka Streams API and KSQLDB, which enabled data processing in event streaming pipelines. It also allowed for data transformations such as mapping, filtering, formatting, aggregating, and outputting the transformed data to downstream stream processors. On the other hand, KSQLDB provided an interactive framework for performing stream processing activities like data aggregation, filtering, joining, and windowing. The processed data underwent continuous transformations, known as stream processing, while the information was updated continuously.

The “Flexmeter” smart metering platform proposed in [25] utilises a cloud-based architecture consisting of distinct layers and modules for efficient data management and communication. The Device Integration Layer enables interoperability among communication technologies through Device Integration Adapters (DIAs), converting measurements into a standardised format. The Middleware Layer includes a Message Broker and Inbound Pipeline for asynchronous bidirectional communication with devices via MQTT. The Data Storage Module manages connections with InfluxDB and MongoDB which are designed for big data management. The proposed architecture allowed the integration of two real-time services: the State Estimation (SE) service and the Network Reconfiguration (NR) service. SE service aims to obtain reliable monitoring of the grid status, while NR service aims to provide faster recovery times and increased resiliency of distribution networks. The experimental tests showed that the proposed approach was able to provide reliable state estimation and network topology reconfiguration functionalities while being scalable and flexible.

The discussed cloud-based system architecture in [26] involves four layers: Smart Meters for data collection, the gateway component for local processing and communication, the Big Data Cloud Platform for machine learning and analytics, and the Application and Visualisation Component for end-user information. The gateway communicates with Amazon Web Services (AWS) IoT via MQTT over WebSocket. Data is sent to AWS Kinesis for real-time processing, with AWS EMR clusters handling data directly from Kinesis streams, supported by DynamoDB for metadata. AWS services were chosen for their comprehensive toolset, and the application component utilises Amazon QuickSight for data visualisation. Experimental validation integrated system components and collected data to create datasets.

In the study [27], the authors build upon the proposed event-streaming architecture introduced in [23]. However, the primary aim of this research was to establish a reference framework for future

evaluations or assessments of smart meter data collection performance. They proposed five formulas designed to calculate different performance indicators, thereby facilitating the determination of the operational efficiency of smart meters. Additionally, the authors highlighted the importance of implementing data retention policies, as accumulating data over time could lead to deteriorating conditions and elevate the risk of performance failure. Authors of [28] also proposed a comprehensive assessment procedure for AMI system evaluation in the early stages of deployment.

Our previous research [29] also investigated the possibility of using Apache Kafka as an event-streaming method for real-time communication between system components. While the proposed approach did boost computation performance, we faced some delays because of the limitations of this particular message broker, especially when a specific processing order or priority was needed. As a result, it is essential to consider how message brokers are used in meter data management systems, considering the different requirements for various communication adapters.

The primary focus of work [30] centres around addressing the challenge of lost data traceability in data stream processing. The author explores the feasibility of incorporating streaming provenance to effectively trace output data back to its source, thereby enhancing transparency and reliability in load forecasts. Experimental findings indicate that the integration of provenance results in a 10.4 % decrease in throughput, an 8.8 % increase in memory consumption, a 10.4 % rise in latency, and a substantial 238.1 % increase in CPU utilisation. Despite these performance impacts, the importance of provenance remains significant, as it enables tracing data origins and processing steps. This capability proves especially valuable in detecting faulty meters within smart grid systems and other similar applications, albeit with some performance degradation.

Similar research was conducted in [31], where data provenance alongside other methods was used to find faulty smart meters in an energy distribution network. Experimental findings in this study also showed a decrease in throughput between 22–34 % and a latency increase between 24–42 %. However, the authors came to the same conclusion that stream processing with provenance indeed emerges as a promising alternative for analysis in AMI contexts due to its potential to significantly mitigate the storage requirements of meter data.

Authors of [32] presented an AMI architecture based on the fog computing paradigm, designed to enable efficient real-time communication between smart meters and cloud servers. The proposed design includes different local metering components (LMCs), tiered computing resources, and cloud infrastructure for real-time monitoring and control to improve energy efficiency and customer services. The authors conducted experiments to demonstrate the effectiveness of their proposed design in terms of load profile data acquisition and communication times. The results showed that the proposed design achieved real-time performance, with load profile data becoming available at the MDC layer after a seven-minute interval, which is well before the next sampling instance given at the rate of 15 minutes.

While research [33] is not directly related to smart grid solutions, it demonstrates approaches for enhancing the performance of real-time big data stateful streaming applications by using Redis cache and MongoDB database for storing and accessing interim results in stateful Spark streaming applications. The same applies to work [34]. It mentions that stream processing of big data presents numerous challenges, including handling high volume, velocity, variety, and veracity of data and ensuring real-time response, fault tolerance, scalability, and state management. Various distributed stream processing systems, including Apache Storm, Spark Streaming, Samza, and Flink, have emerged to address these challenges. These systems offer different processing models, stream primitives, latency, throughput, state management, delivery guarantees, and programming APIs. The authors highlighted that the selection of a stream processing system hinges on the specific requirements and characteristics of the application domain, including data sources, processing logic, quality of service, and cost constraints.

Study [35] explores big data parallel processing performance using Apache Spark for load forecasting. Authors discovered that standalone machine learning surpasses distributed computing with Spark when data fits into a single node's memory. However, Spark outperforms standalone methods due to

reduced resource distribution overhead, especially with large datasets, provided there is enough memory for successful non-distributed execution. Performance in a Spark cluster improves with increased nodes, peaking between 4 and 8 cores per node. Excessive memory does not necessarily reduce execution time. The authors continued their research with the study [36], delving deeper into big data processing approaches and comprehensively reviewing several computation models. They also proposed big data architecture for smart grids utilising Apache Hadoop. This architecture consists of three main layers – data collection, storage, and data mining and analytics. One of the main goals of this solution is to enable the integration of different data sources from smart grids, such as smart meters, sensors, and other devices. This integration will provide more comprehensive and accurate insights into grid operations, energy consumption patterns, and consumer behaviour. Another objective is to improve the scalability and flexibility of smart grid data management, allowing utilities to handle large and growing volumes of data and support various use cases.

While researching topics on real-time distributed systems, it is essential to review existing proposed solutions from other industries. For instance, the study [37] describes Uber’s real-time infrastructure in great detail, explaining all constraints and considerations for choosing specific data streaming, storage, and analytics technologies. With an optimised stack, Uber’s real-time data infrastructure handles multiple petabytes daily. Open-source technologies like Kafka and Flink enable seamless data processing and high availability. Pinot provides low-latency OLAP capabilities and Presto integration for real-time data exploration. The flexibility of the infrastructure caters to diverse use cases supported by abstractions like FlinkSQL and PrestoSQL. Future work includes unifying streaming and batch processing, enhancing multi-region deployments, and exploring tiered storage solutions for cost efficiency and elasticity.

From the literature reviewed, two primary applications of real-time data processing approaches emerge: one is centred around optimising data streaming performance, while the other focuses on data analysis. The focus, findings (Table 1) and experimental datasets (Table 2) of these articles are summarized for a clear understanding. This review also highlights the attention given by studies such as [23], [27], and others to the critical aspect of accommodating SLAs within real-time distributed processing approaches, asserting success in meeting these requirements. Despite technological advancements, challenges persist in achieving optimal data processing efficiency, latency management, throughput optimization, and high availability and reliability in smart grid environments. Insights from other industries, such as Uber’s innovative approaches, underscore the potential for leveraging external examples to enhance smart grid solutions. Therefore, while progress has been significant, there remains room for improvement and exploration of novel strategies to meet the evolving demands of smart grid environments.

*Table 1*

**Summary of the literature reviewed**

Work	Year	Focus	Findings
[23]	2021	Real-time data processing using <b>event-streaming</b> utilizing <b>Apache Kafka</b>	<ul style="list-style-type: none"> <li>• The proposed event-streaming approach enhanced overall system performance compared to the previous design – batch processing.</li> <li>• Experimental findings indicate that the system effectively operates within the required SLA</li> </ul>
[24]	2023	Real-time data ETL process using <b>event-streaming</b> utilizing <b>Apache Kafka</b>	<ul style="list-style-type: none"> <li>• Explores the methodology for extracting and loading data from low voltage distribution networks and its application in AMI</li> </ul>
[25]	2018	Real-time data processing using an <b>event-driven</b> approach utilizing <b>Message Broker, InfluxDB, and MongoDB</b>	<ul style="list-style-type: none"> <li>• Experimental results show that the proposed system can perform all the steps of the multi-level Distribution System State Estimation (DSSE) within a few seconds, and satisfies the communication requirements of classes TT0, TT1, and TT2 defined by the IEC 61850 standard</li> </ul>

## Summary of the literature reviewed

Work	Year	Focus	Findings
[26]	2019	Real-time data processing utilizing cloud solutions such as <b>AWS IoT</b> , <b>AWS Kinesis</b> , <b>AWS EMR</b> , and <b>DynamoDB</b>	<ul style="list-style-type: none"> <li>The experimental validation was focused on the integration of the system components and data collection to create datasets for future research</li> </ul>
[27]	2023	Assessment framework to determine the operational efficiency of smart meters	<ul style="list-style-type: none"> <li>Proposed measurement criteria of smart meters performance based on their function, ranging from installation, registration, connection, disconnection, reregistration, and post-installation activities</li> </ul>
[28]	2021	Smart meter data collection performance evaluations	<ul style="list-style-type: none"> <li>Proposed several formulas to evaluate smart meters' communication performance</li> </ul>
[29]	2023	Real-time data processing using <b>event-streaming</b> utilizing <b>Apache Kafka</b>	<ul style="list-style-type: none"> <li>The experimental results showed that the approach with a message broker enhanced performance compared to batch processing.</li> <li>Further research is aimed at enhancing existing or developing new computational models based on a distributed computing system to reduce computation delays.</li> </ul>
[30]	2023	Real-time data streaming provenance utilizing <b>Apache Kafka</b> , <b>Apache Flink</b> , <b>Ananke</b> , and <b>InfluxDB</b>	<ul style="list-style-type: none"> <li>Implementing Ananke posed challenges in dealing with performance trade-offs associated with the transparent version.</li> <li>Evaluation limitations were observed, including constraints imposed by fixed dataset sizes and the presence of missing data from InfluxDB</li> </ul>
[31]	2022	Real-time data streaming provenance utilizing <b>Apache Flink</b> and <b>GeneaLog</b>	<ul style="list-style-type: none"> <li>Queries enriched with advanced provenance capture from extended GeneaLog proved effective in identifying common faults within smart meters.</li> <li>Real-world AMI data assessment showed varying query performance, with manageable overall overhead from provenance but some queries suffering significant latency and memory issues.</li> <li>Stream processing coupled with provenance capture showcased significant potential in reducing storage requirements, particularly for non-billing data</li> </ul>
[32]	2022	Real-time communication between smart meters and the cloud servers using agent-based <b>fog computing</b>	<ul style="list-style-type: none"> <li>Experimental results confirm the system's ability to deliver metering data in real-time across all tiers of the AMI.</li> <li>Authors acknowledge security and manageability challenges inherent in distributed AMI architecture, such as ensuring data confidentiality and managing node lifecycle</li> </ul>
[33]	2022	Enhancing the performance of real-time cloud big data stateful streaming applications utilizing <b>Redis</b> and <b>MongoDB</b>	<ul style="list-style-type: none"> <li>The optimization of memory access and utilizing in-memory caching techniques, such as Redis cache or high-performance databases like MongoDB, can improve the performance of real-time big data stateful streaming applications.</li> </ul>
[34]	2019	Big data stream processing utilizing <b>Apache Storm</b> , <b>Spark Streaming</b> , <b>Samza</b> , and <b>Apache Flink</b>	<ul style="list-style-type: none"> <li>Comprehensive review and comparison of stream processing frameworks such as Apache Storm, Spark, Samza, and Flink.</li> <li>There is no one-size-fits-all framework that is best for everybody.</li> <li>It is recommended that users evaluate their specific requirements carefully and choose a framework that best meets their needs</li> </ul>

Table 1 (continued).

Summary of the literature reviewed

Work	Year	Focus	Findings
[35]	2020	Big data parallel processing utilising <b>Apache Spark</b>	<ul style="list-style-type: none"> <li>Experimental results indicate that non-Spark standalone machine learning performs better than Spark when the data fits into one node’s memory. However, Spark outperforms in the case of larger datasets due to reduced resource distribution overhead</li> </ul>
[36]	2021	Big data parallel processing utilising <b>Apache Hadoop</b> and <b>Apache Spark</b>	<ul style="list-style-type: none"> <li>Key technologies such as Hadoop, MapReduce, HDFS, HopsFS, and Apache Spark are used for storing, processing, and analysing smart grid data, each with its strengths and limitations.</li> <li>NoSQL databases are preferred for big data applications due to their scalability and performance advantages</li> </ul>
[37]	2021	Real-time data streaming infrastructure utilizing <b>Apache Kafka</b> and <b>Apache Flink</b>	<ul style="list-style-type: none"> <li>Uber implements surge pricing using a streaming pipeline that ingests data from Kafka, processes it with a machine-learning algorithm in Flink, and stores results in a key-value store for quick lookup.</li> <li>The system prioritizes data freshness and availability over consistency, with strict end-to-end latency requirements.</li> <li>Design trade-offs include using a Kafka cluster configured for higher throughput but not lossless guarantee, and an active-active setup for higher availability</li> </ul>

Table 2

Experimental datasets from reviewed literature

Work	Smart meters	Dataset	Interval	Expected load per hour
[23]	1191	Readings of energy consumption	15 minutes	4764
[27]	103615	Readings of energy consumption	15 minutes	414460
[30]	10	Readings of energy consumption	N/A	N/A
[31]	282000	Readings of energy consumption	1 hour	300000
		Voltage and current for three phases	~ 12 hours	25000

Understanding data origins and volumes

The smart grid ecosystem comprises a multitude of data sources, ranging from SCADA systems [38] to AMI, smart meters, sensors, Phasor Measurement Units (PMUs), distributed generation units, weather data, and customer information [36, 39]. These diverse data sources collectively generate large volumes of real-time data, reflecting various aspects of the grid’s operational status and environmental conditions. The data collected from these sources is transmitted securely to centralised servers or cloud platforms through dedicated channels, ensuring the integrity and confidentiality of the information [39].

In a typical AMI deployment [17] (Fig. 1, *a*), smart meters transmit raw readings to Data Concentrator Units (DCUs), which in turn relay meter data to Head-End Systems (HES). Alternatively, modified smart grid deployments [40] could utilize radio mesh (Fig. 1, *b*) and various device modules, allowing meters to transmit data directly to HES or serve as relays for forwarding meter values. Following preprocessing in HES, meter data is forwarded to the Meter Data Management System (MDMS).

Communication networks facilitate the transmission of interval consumption data from the meter to the utility back offices. The MDMS plays a crucial role in managing the increased volume of data, integrating meter data with various information and control systems, such as head-end systems, billing systems, customer information systems, geographic information systems, outage management systems, and distribution

management systems. Additionally, in an AMI setup, data collection is not limited to electricity consumption alone; water, gas, or heat meters may also contribute, necessitating robust data management and integration strategies within the AMI infrastructure for comprehensive utility management.

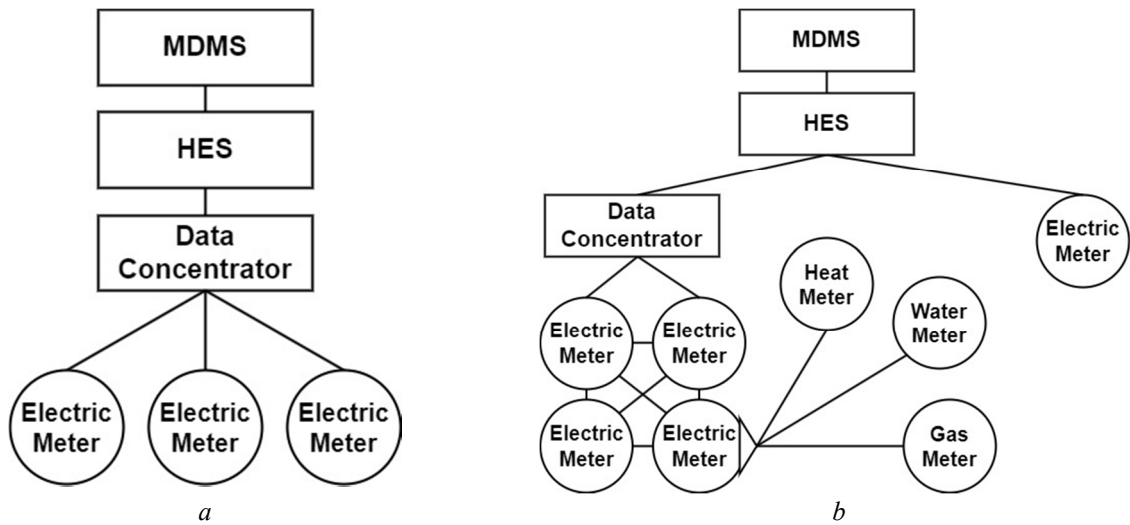

Fig. 1. AMI deployment. (a) Typical AMI deployment. (b) Radio Mesh AMI deployment

Smart meters typically gather electricity consumption data at intervals of an hour or less, varying from 5 to 60 minutes (Table 3). It's essential to differentiate between big data and large data volumes concerning meter data collection and processing. Large data volumes simply refer to the sheer amount of data generated by smart meters and similar devices. On the other hand, big data encompasses not just the volume but also factors like value, variety, velocity, and variability of data [41]. This means effective management and processing of meter data demand scalable and efficient big data analytics techniques. These methods should handle various data sources, process large volumes of data in real-time, and extract valuable insights to aid decision-making in smart grid systems.

Table 3

**Expected data load for 1000 smart meters**

Data collection interval, minutes	Number of readings		
	1 hour	1 day	1 week
5	12000	288000	2016000
15	4000	96000	672000
30	2000	48000	336000
60	1000	24000	168000

**Discussions and further research**

In the domain of smart meter data processing and management, current scientific researches focus on improving key metrics like throughput and latency, data analysis quality, or overall operational efficiency, reliability, security, and sustainability. Notably, energy consumption estimation, energy loss detection, load forecasting, and anomaly detection have been significant areas of investigation.

Energy consumption estimation techniques aim to accurately predict future energy usage patterns, aiding in resource planning and optimization [42]. Similarly, energy loss detection methodologies help identify inefficiencies and losses in distribution systems, facilitating improvements in system performance and reliability [43].

Load forecasting techniques play a crucial role in predicting future electricity demand, enabling utilities to effectively plan and manage their resources to meet consumer needs [15, 16, 32, 44, 45]. These



forecasts are essential for optimizing generation, transmission, and distribution operations, ensuring grid stability and reliability.

Anomaly detection methods [46] focus on identifying abnormal behaviour or events within smart grid systems, including cyber-attacks [47, 48], device faults [31], theft [49, 50], or false data injection [13]. Detecting and mitigating such anomalies is vital for maintaining system integrity, security, and resilience.

Moving forward, future research may focus on developing new or enhancing existing real-time processing methods suitable for handling large volumes of data in smart metering. Additionally, other potential areas for investigation might include enhancing data traceability in real-time data stream processing, drawing upon insights from studies such as those outlined in [30] and [31], among various other potential tasks.

### **Conclusions**

The growing data volumes within Advanced Metering Infrastructure (AMI) systems highlight the importance of managing data effectively to meet established Service Level Agreements (SLAs). This study comprehensively reviews the latest real-time data processing and analysis methods and technologies relevant to smart grid applications outlining the following findings:

- Increased data load is driven by the widespread smart meter installations and more frequent data collection (sub-hourly intervals). Despite existing data processing approaches maintaining functionality under a rising load, challenges related to various performance, accuracy, and scalability metrics persist.
- Both event-driven processing and data stream processing approaches could be used for data ingestion as well as for other tasks. For instance, some studies integrated stream processing to implement load forecasting and faulty meter detection, which showcased potential in reducing storage requirements.
- Event-driven processing approaches provide very low latency in data transmission and outperform batch processing. However, this approach could introduce challenges as some message brokers may not support built-in ordering.
- Data stream processing approaches also outperform batch processing but add additional computing overhead (memory and CPU usage).
- Challenges related to security and manageability are inherent in distributed architectures.
- Insights from other industries that deal with large real-time data volumes, such as those derived from Uber and others, offer valuable perspectives for enhancing smart grid solutions.

Future research should focus on the challenges identified in the reviewed studies to ensure the scalability of smart grid systems and enhance existing methods to meet dynamic SLAs effectively. One of the possible problems that could be investigated in more detail is improving data traceability methods in real-time data stream processing.

### **Acknowledgements**

We extend our gratitude to Mykola Morozov and Pavlo Pustelnyk for their invaluable assistance with the initial stages of this research. Their expertise and support were instrumental in shaping the direction and scope of our study.

### **Conflict of interest**

The authors declare that the research was conducted without any commercial or financial relationships that could be construed as a potential conflict of interest.

### **References**

1. Hassan, A., Afrouzi, H. N., Siang, C. H., Ahmed, J., Mehranzamir, K., & Wooi, C.-L. (2022). A survey and bibliometric analysis of different communication technologies available for smart meters. *Cleaner Engineering and Technology*, 7, 100424. <https://doi.org/10.1016/j.clet.2022.100424>

2. Tightiz, L., & Yang, H. (2020). A comprehensive review on IOT protocols' features in Smart Grid Communication. *Energies*, 13(11), 2762. <https://doi.org/10.3390/en13112762>
3. Sikic, L., Jankovic, J., Afric, P., Silic, M., Ilic, Z., Pandzic, H., Zivic, M., & Dzanko, M. (2020). A comparison of application layer communication protocols in IOT-enabled Smart Grid. 2020 International Symposium ELMAR. <https://doi.org/10.1109/elmar49956.2020.9219030>
4. Lombardi, M., Pascale, F., & Santaniello, D. (2021). Internet of things: A general overview between architectures, protocols and applications. *Information*, 12(2), 87. <https://doi.org/10.3390/info12020087>
5. Khan, B., & Pirak, C. (2021). Experimental Performance Analysis of MQTT and CoAP protocol usage for Nb-IOT Smart meter. 2021 9th International Electrical Engineering Congress (iEECON). <https://doi.org/10.1109/ieecon51072.2021.9440273>
6. Anani, W., & Ouda, A. (2022). Wireless meter bus: Secure remote metering within the IOT smart grid. 2022 International Symposium on Networks, Computers and Communications (ISNCC). <https://doi.org/10.1109/isncc55209.2022.9851807>
7. Office of Electricity Delivery and Energy Reliability. Advanced Metering Infrastructure and Customer Systems – Results from the Smart Grid Investment Grant Program (2016, September). [https://www.energy.gov/sites/prod/files/2016/12/f34/AMI%20Summary%20Report\\_09-26-16.pdf](https://www.energy.gov/sites/prod/files/2016/12/f34/AMI%20Summary%20Report_09-26-16.pdf)
8. Dey, A., Chakraborty, B., Dalai, S., & Bhattacharya, K. (2022). Insights and new practices for advanced metering infrastructure and smart energy metering framework in smart grid- A case study. 2022 IEEE Calcutta Conference (CALCON). <https://doi.org/10.1109/calcon56258.2022.10060514>
9. Definition of Advanced Metering Infrastructure (AMI) - Gartner Information Technology Glossary. (n. d.). Gartner. <https://www.gartner.com/en/information-technology/glossary/advanced-metering-infrastructure-ami>
10. Carou Álvarez, J. M., & Ramón, L. S. (2023). Smart meters. *Encyclopedia of Electrical and Electronic Power Engineering*, 441–447. <https://doi.org/10.1016/b978-0-12-821204-2.00067-2>
11. Kumar, A., Thakur, S., & Bhattacharjee, P. (2018b). Real time monitoring of AMR enabled energy meter for AMI in Smart City – an IOT application. 2018 IEEE International Symposium on Smart Electronic Systems (iSES) (Formerly iNiS). <https://doi.org/10.1109/ises.2018.00055>
12. Huang, J.-F., Zhang, G.-H., & Hsieh, S.-Y. (2021). Real-time energy data compression strategy for reducing data traffic based on Smart Grid AMI Networks. *The Journal of Supercomputing*, 77(9), 10097–10116. <https://doi.org/10.1007/s11227-020-03557-8>
13. Abdulaal, M. J., Ibrahim, M. I., Mahmoud, M. M., Khalid, J., Aljohani, A. J., Milyani, A. H., & Abusorrah, A. M. (2022). Real-time detection of false readings in Smart Grid AMI using deep and ensemble learning. *IEEE Access*, 10, 47541–47556. <https://doi.org/10.1109/access.2022.3171262>
14. Zhou, S. (2021). The effect of smart meter penetration on dynamic electricity pricing: Evidence from the United States. *The Electricity Journal*, 34(3), 106919. <https://doi.org/10.1016/j.tej.2021.106919>
15. Mansoor, H., Ali, S., Khan, I. U., Arshad, N., Khan, M. A., & Faizullah, S. (2023). Short-term load forecasting using AMI data. *IEEE Internet of Things Journal*, 1–1. <https://doi.org/10.1109/jiot.2023.3295617>
16. Huang, C.-M., Huang, Y.-C., Chen, S.-J., Yang, S.-P., & Huang, K.-Y. (2021). Ami load forecasting and interval forecasting using a hybrid intelligent method. 2021 IEEE 30th International Symposium on Industrial Electronics (ISIE). <https://doi.org/10.1109/isie45552.2021.9576343>
17. Gold, R., Waters, C., & York, D. (2020). Leveraging advanced metering infrastructure to save energy. Washington DC: American Council for an Energy-Efficient Economy (ACEEE).
18. Frequently Asked Questions (FAQs) – U.S. Energy Information Administration (EIA) (2023, October 20). Homepage – U.S. Energy Information Administration (EIA). <https://www.eia.gov/tools/faqs/faq.php?id=108&t=3>
19. Kotsar, O. (2018). The development of Smart Systems for control, metering and energy management in liberalized electricity market of Ukraine. *Tekhnichna Elektrodynamika*, 2018(4), 110–117. <https://doi.org/10.15407/techned2018.04.110>
20. Chukut, S., & Shumska, L. (2022). Introducing smart grid as part of a smart city using big data: current challenges and trends. *Investytsiyi: Praktyka Ta Dosvid*, (3), 88–95. <https://doi.org/10.32702/2306-6814.2022.3.88>
21. Petko, S. (2023). The Republic of Korea experience of “smart-grid” implementing in the post-war recovery of Ukrainian Energy System. *Marketing and Digital Technologies*, 7(2), 8–18. <https://doi.org/10.15276/mdt.7.2.2023.1>
22. 15 min imbalance settlement period in Norway and Sweden. eSett. (2023, May 5). <https://www.esett.com/news/15-min-imbalance-settlement-period-in-norway-and-sweden/>

23. Rendroyoko, I., Setiawan, A. D., & Suhardi, S. (2021). Development of meter data management system based-on event-driven streaming architecture for IOT-based AMI implementation. 2021 3rd International Conference on High Voltage Engineering and Power Systems (ICHVEPS). <https://doi.org/10.1109/ichveps53178.2021.9601104>
24. Dutta, S., Miranda, A., & Arboleya, P. (2023). Real-time data extraction, transformation and loading process for LV Advanced Distribution Management Systems. 2023 IEEE Belgrade PowerTech. <https://doi.org/10.1109/powertech55446.2023.10202807>
25. Pau, M., Patti, E., Barbierato, L., Estebarsari, A., Pons, E., Ponci, F., & Monti, A. (2018). A cloud-based smart metering infrastructure for distribution grid services and automation. *Sustainable Energy, Grids and Networks*, 15, 14–25. <https://doi.org/10.1016/j.segan.2017.08.001>
26. Pires, F. M., Leon Quinonez, L., & de Souza Mendes, L. (2019). A cloud-based system architecture for advanced metering in smart cities. 2019 IEEE 10th Annual Information Technology, Electronics and Mobile Communication Conference (IEMCON). <https://doi.org/10.1109/iemcon.2019.8936283>
27. Prakoso, M. H., Irawan, F., Sufianto, A. M., & Rediansyah, D. (2023). Comprehensive assessment of small batch advanced metering infrastructure utilisation on Java region to support Indonesian smart grid systems. 2023 4th International Conference on High Voltage Engineering and Power Systems (ICHVEPS). <https://doi.org/10.1109/ichveps58902.2023.10257557>
28. Anugrahany, E., Supriyadi, G., Nugraha, D. A., W, O. P., & Mafruddin, M. M. (2021). Assessment procedure for advanced metering infrastructure implementation in Indonesia. 2021 3rd International Conference on High Voltage Engineering and Power Systems (ICHVEPS). <https://doi.org/10.1109/ichveps53178.2021.9601053>
29. Moravskiy, R., Pustelnyk, P., Morozov, M., & Levus, Y. (2023). Cloud-based distributed approach for procedural terrain generation with enhanced performance. 2023 IEEE 18th International Conference on Computer Science and Information Technologies (CSIT). <https://doi.org/10.1109/csit61576.2023.10324223>
30. Mohamed, Z. (2023, November 24). (thesis). Data streaming provenance in advanced metering infrastructures. Retrieved February 21, 2024, from <https://hdl.handle.net/2077/79292>.
31. Taube, J., & Johnsson, W. (2022). (thesis). Streaming Analytics with Provenance in the Advanced Metering Infrastructure. Retrieved March 3, 2024, from <https://odr.chalmers.se/handle/20.500.12380/305852>
32. Popović, I., Rakić, A., & Petruševski, I. D. (2022). Multi-agent real-time advanced metering infrastructure based on Fog Computing. *Energies*, 15(1), 373. <https://doi.org/10.3390/en15010373>
33. Gupta, A., & Jain, S. (2022). Optimising performance of real-time big data stateful streaming applications on cloud. 2022 IEEE International Conference on Big Data and Smart Computing (BigComp). <https://doi.org/10.1109/bigcomp54360.2022.00010>
34. Tantalaki, N., Souravlas, S., & Roumeliotis, M. (2019). A review on big data real-time stream processing and its scheduling techniques. *International Journal of Parallel, Emergent and Distributed Systems*, 35(5), 571–601. <https://doi.org/10.1080/17445760.2019.1585848>
35. Zainab, A., Refaat, S. S., Abu-Rub, H., & Bouhali, O. (2020). Distributed computing for smart meter data management for electrical utility applications. 2020 *Cybernetics & Informatics (K&I)*. <https://doi.org/10.1109/ki48306.2020.9039899>
36. Zainab, A., Ghrayeb, A., Syed, D., Abu-Rub, H., Refaat, S. S., & Bouhali, O. (2021). Big Data Management in smart grids: Technologies and challenges. *IEEE Access*, 9, 73046–73059. <https://doi.org/10.1109/access.2021.3080433>
37. Fu, Y., & Soman, C. (2021). Real-time data infrastructure at Uber. Proceedings of the 2021 International Conference on Management of Data. <https://doi.org/10.1145/3448016.3457552>
38. Pandit, R., Astolfi, D., Hong, J., Infield, D., & Santos, M. (2022). SCADA data for wind turbine data-driven condition/performance monitoring: A review on state-of-art, challenges and future trends. *Wind Engineering*, 47(2), 422–441. <https://doi.org/10.1177/0309524x221124031>
39. Cheng, G., Lin, Y., Abur, A., Gómez-Expósito, A., & Wu, W. (2024). A survey of power system state estimation using multiple data sources: Pmus, SCADA, Ami, and beyond. *IEEE Transactions on Smart Grid*, 15(1), 1129–1151. <https://doi.org/10.1109/tsg.2023.3286401>
40. Shrestha, M., Johansen, C., Noll, J., & Roverso, D. (2020). A methodology for security classification applied to Smart Grid Infrastructures. *International Journal of Critical Infrastructure Protection*, 28, 100342. <https://doi.org/10.1016/j.ijcip.2020.100342>
41. Amović, M., Govedarica, M., Radulović, A., & Janković, I. (2021). Big Data in smart city: Management challenges. *Applied Sciences*, 11(10), 4557. <https://doi.org/10.3390/app11104557>

42. Güçyetmez, M., & Farhan, H. S. (2023). Enhancing smart grids with a new IOT and cloud-based smart meter to predict the energy consumption with time series. *Alexandria Engineering Journal*, 79, 44–55. <https://doi.org/10.1016/j.aej.2023.07.071>
43. Schulz, D., Lawanson, T., Ravikumar, K., & Cecchi, V. (2020). Loss estimation and visualization in distribution systems using AMI and Recloser Data. 2020 IEEE/PES Transmission and Distribution Conference and Exposition (T&D). <https://doi.org/10.1109/td39804.2020.9299891>
44. Deng, B., Wen, Y., & Yuan, P. (2020). Hybrid short-term load forecasting using the Hadoop MapReduce framework. 2020 IEEE Power & Energy Society General Meeting (PESGM). <https://doi.org/10.1109/pesgm41954.2020.9282094>
45. Hu, L., Zhang, L., Wang, T., & Li, K. (2020). Short-term load forecasting based on support vector regression considering cooling load in summer. 2020 Chinese Control And Decision Conference (CCDC). <https://doi.org/10.1109/ccdc49329.2020.9164387>
46. Banik, S., Saha, S. K., Banik, T., & Hossain, S. M. (2023). Anomaly detection techniques in Smart Grid Systems: A Review. 2023 IEEE World AI IoT Congress (AIoT). <https://doi.org/10.1109/aiiot58121.2023.10174485>
47. Ibrahim, M. I., Abdelfattah, S., Mahmoud, M., & Alasmary, W. (2021). Detecting electricity theft cyber-attacks in Cat Ami System using machine learning. 2021 International Symposium on Networks, Computers and Communications (ISNCC). <https://doi.org/10.1109/isncc52172.2021.9615629>
48. Takiddin, A., Ismail, M., Zafar, U., & Serpedin, E. (2021). Variational auto-encoder-based detection of electricity stealth cyber-attacks in Ami Networks. 2020 28th European Signal Processing Conference (EUSIPCO). <https://doi.org/10.23919/eusipco47968.2020.9287764>
49. Qi, R., Zheng, J., Luo, Z., & Li, Q. (2022). A novel unsupervised data-driven method for electricity theft detection in Ami using observer meters. *IEEE Transactions on Instrumentation and Measurement*, 71, 1–10. <https://doi.org/10.1109/tim.2022.3189748>
50. M. Jahid Hasan, A. S., Rahman, M. S., Islam, M. S., & Yusuf, J. (2023). Data Driven Energy theft localization in a distribution network. 2023 International Conference on Information and Communication Technology for Sustainable Development (ICICT4SD). <https://doi.org/10.1109/icict4sd59951.2023.10303520>

#### Список літератури

1. Hassan, A., Afrouzi, H. N., Siang, C. H., Ahmed, J., Mehranzamir, K., & Wooi, C.-L. (2022). A survey and bibliometric analysis of different communication technologies available for smart meters. *Cleaner Engineering and Technology*, 7, 100424. <https://doi.org/10.1016/j.clet.2022.100424>
2. Tightiz, L., & Yang, H. (2020). A comprehensive review on IOT protocols' features in Smart Grid Communication. *Energies*, 13(11), 2762. <https://doi.org/10.3390/en13112762>
3. Sikic, L., Jankovic, J., Afric, P., Silic, M., Ilic, Z., Pandzic, H., Zivic, M., & Dzanko, M. (2020). A comparison of application layer communication protocols in IOT-enabled Smart Grid. 2020 International Symposium ELMAR. <https://doi.org/10.1109/elmar49956.2020.9219030>
4. Lombardi, M., Pascale, F., & Santaniello, D. (2021). Internet of things: A general overview between architectures, protocols and applications. *Information*, 12(2), 87. <https://doi.org/10.3390/info12020087>
5. Khan, B., & Pirak, C. (2021). Experimental Performance Analysis of MQTT and CoAP protocol usage for Nb-IOT Smart meter. 2021 9th International Electrical Engineering Congress (iEECON). <https://doi.org/10.1109/ieecon51072.2021.9440273>
6. Anani, W., & Ouda, A. (2022). Wireless meter bus: Secure remote metering within the IOT smart grid. 2022 International Symposium on Networks, Computers and Communications (ISNCC). <https://doi.org/10.1109/isncc55209.2022.9851807>
7. Advanced Metering Infrastructure and Customer Systems - Results from the Smart Grid Investment Grant Program. (2016, вересень). Office of Electricity Delivery and Energy Reliability. [https://www.energy.gov/sites/prod/files/2016/12/f34/AMI%20Summary%20Report\\_09-26-16.pdf](https://www.energy.gov/sites/prod/files/2016/12/f34/AMI%20Summary%20Report_09-26-16.pdf)
8. Dey, A., Chakraborty, B., Dalai, S., & Bhattacharya, K. (2022). Insights and new practices for advanced metering infrastructure and smart energy metering framework in smart grid- A case study. 2022 IEEE Calcutta Conference (CALCON). <https://doi.org/10.1109/calcon56258.2022.10060514>
9. Definition of Advanced Metering Infrastructure (AMI) – Gartner Information Technology Glossary (6. д.). Gartner. <https://www.gartner.com/en/information-technology/glossary/advanced-metering-infrastructure-ami>
10. Carou Álvarez, J. M., & Ramón, L. S. (2023). Smart meters. *Encyclopedia of Electrical and Electronic Power Engineering*, 441–447. <https://doi.org/10.1016/b978-0-12-821204-2.00067-2>

11. Kumar, A., Thakur, S., & Bhattacharjee, P. (2018b). Real time monitoring of AMR enabled energy meter for AMI in Smart City – an IOT application. 2018 IEEE International Symposium on Smart Electronic Systems (iSES) (Formerly iNiS). <https://doi.org/10.1109/ises.2018.00055>
12. Huang, J.-F., Zhang, G.-H., & Hsieh, S.-Y. (2021). Real-time energy data compression strategy for reducing data traffic based on Smart Grid AMI Networks. *The Journal of Supercomputing*, 77(9), 10097–10116. <https://doi.org/10.1007/s11227-020-03557-8>
13. Abdulaal, M. J., Ibrahim, M. I., Mahmoud, M. M., Khalid, J., Aljohani, A. J., Milyani, A. H., & Abusorrah, A. M. (2022). Real-time detection of false readings in Smart Grid AMI using deep and ensemble learning. *IEEE Access*, 10, 47541–47556. <https://doi.org/10.1109/access.2022.3171262>
14. Zhou, S. (2021). The effect of smart meter penetration on dynamic electricity pricing: Evidence from the United States. *The Electricity Journal*, 34(3), 106919. <https://doi.org/10.1016/j.tej.2021.106919>
15. Mansoor, H., Ali, S., Khan, I. U., Arshad, N., Khan, M. A., & Faizullah, S. (2023). Short-term load forecasting using AMI data. *IEEE Internet of Things Journal*, 1–1. <https://doi.org/10.1109/jiot.2023.3295617>
16. Huang, C.-M., Huang, Y.-C., Chen, S.-J., Yang, S.-P., & Huang, K.-Y. (2021). Ami load forecasting and interval forecasting using a hybrid intelligent method. 2021 IEEE 30th International Symposium on Industrial Electronics (ISIE). <https://doi.org/10.1109/isie45552.2021.9576343>
17. Gold, R., Waters, C., & York, D. (2020). Leveraging advanced metering infrastructure to save energy. Washington DC: American Council for an Energy-Efficient Economy (ACEEE).
18. Frequently Asked Questions (FAQs) – U.S. Energy Information Administration (EIA). (2020, 20 жовтня). Homepage – U. S. Energy Information Administration (EIA). <https://www.eia.gov/tools/faqs/faq.php?id=108&t=3>
19. Коцар, О. (2022). Розвиток автоматизованих систем комерційного обліку електроенергії в умовах лібералізації ринку електричної енергії України. *Технічна електродинаміка*, 2018(4), 110-117. <https://doi.org/10.15407/techned2018.04.110>
20. Чукут, С., & Шумська, Л. (2022). Запровадження розумних енергосистем як складової розумного міста з використанням великих даних: сучасні виклики та тенденції. *Інвестиції: практика та досвід*, (3), 88–95. <https://doi.org/10.32702/2306-6814.2022.3.88>
21. Петько, С. (2023). Південнокорейський досвід імплементації “розумних мереж” у післявоєнному відновленні української енергосистеми. *Маркетинг і цифрові технології*, 7(2), 8–18. <https://doi.org/10.15276/mdt.7.2.2023.1>
22. 15 min imbalance settlement period in Norway and Sweden – eSett. (2023, 5 травня). eSett. <https://www.esett.com/news/15-min-imbalance-settlement-period-in-norway-and-sweden>
23. Rendroyoko, I., Setiawan, A. D., & Suhardi, S. (2021). Development of meter data management system based-on event-driven streaming architecture for IOT-based AMI implementation. 2021 3rd International Conference on High Voltage Engineering and Power Systems (ICHVEPS). <https://doi.org/10.1109/ichveps53178.2021.9601104>
24. Dutta, S., Miranda, A., & Arboleya, P. (2023). Real-time data extraction, transformation and loading process for LV Advanced Distribution Management Systems. 2023 IEEE Belgrade PowerTech. <https://doi.org/10.1109/powertech55446.2023.10202807>
25. Pau, M., Patti, E., Barbierato, L., Estebansari, A., Pons, E., Ponci, F., & Monti, A. (2018). A cloud-based smart metering infrastructure for distribution grid services and automation. *Sustainable Energy, Grids and Networks*, 15, 14–25. <https://doi.org/10.1016/j.segan.2017.08.001>
26. Pires, F. M., Leon Quinonez, L., & de Souza Mendes, L. (2019). A cloud-based system architecture for advanced metering in smart cities. 2019 IEEE 10th Annual Information Technology, Electronics and Mobile Communication Conference (IEMCON). <https://doi.org/10.1109/iemcon.2019.8936283>
27. Prakoso, M. H., Irawan, F., Sufianto, A. M., & Rediansyah, D. (2023). Comprehensive assessment of small batch advanced metering infrastructure utilisation on Java region to support Indonesian smart grid systems. 2023 4th International Conference on High Voltage Engineering and Power Systems (ICHVEPS). <https://doi.org/10.1109/ichveps58902.2023.10257557>
28. Anugrahany, E., Supriyadi, G., Nugraha, D. A., W, O. P., & Mafruddin, M. M. (2021). Assessment procedure for advanced metering infrastructure implementation in Indonesia. 2021 3rd International Conference on High Voltage Engineering and Power Systems (ICHVEPS). <https://doi.org/10.1109/ichveps53178.2021.9601053>
29. Moravskiy, R., Pustelnyk, P., Morozov, M., & Levus, Y. (2023). Cloud-based distributed approach for procedural terrain generation with enhanced performance. 2023 IEEE 18th International Conference on Computer Science and Information Technologies (CSIT). <https://doi.org/10.1109/csit61576.2023.10324223>

30. Mohamed, Z. (2023). Data streaming provenance in advanced metering infrastructures [Магістерська робота, University Of Gothenburg]. <https://hdl.handle.net/2077/79292>
31. Taube, J., & Johnsson, W. (2022). Streaming Analytics with Provenance in the Advanced Metering Infrastructure [Магістерська робота, University Of Gothenburg]. <https://odr.chalmers.se/handle/20.500.12380/305852>
32. Popović, I., Rakić, A., & Petruševski, I. D. (2022). Multi-agent real-time advanced metering infrastructure based on Fog Computing. *Energies*, 15(1), 373. <https://doi.org/10.3390/en15010373>
33. Gupta, A., & Jain, S. (2022). Optimising performance of real-time big data stateful streaming applications on cloud. 2022 IEEE International Conference on Big Data and Smart Computing (BigComp). <https://doi.org/10.1109/bigcomp54360.2022.00010>
34. Tantalaki, N., Souravlas, S., & Roumeliotis, M. (2019). A review on big data real-time stream processing and its scheduling techniques. *International Journal of Parallel, Emergent and Distributed Systems*, 35(5), 571–601. <https://doi.org/10.1080/17445760.2019.1585848>
35. Zainab, A., Refaat, S. S., Abu-Rub, H., & Bouhali, O. (2020). Distributed computing for smart meter data management for electrical utility applications. 2020 *Cybernetics & Informatics (K&I)*. <https://doi.org/10.1109/ki48306.2020.9039899>
36. Zainab, A., Ghrayeb, A., Syed, D., Abu-Rub, H., Refaat, S. S., & Bouhali, O. (2021). Big Data Management in smart grids: Technologies and challenges. *IEEE Access*, 9, 73046–73059. <https://doi.org/10.1109/access.2021.3080433>
37. Fu, Y., & Soman, C. (2021). Real-time data infrastructure at Uber. Proceedings of the 2021 International Conference on Management of Data. <https://doi.org/10.1145/3448016.3457552>
38. Pandit, R., Astolfi, D., Hong, J., Infield, D., & Santos, M. (2022). SCADA data for wind turbine data-driven condition/performance monitoring: A review on state-of-art, challenges and future trends. *Wind Engineering*, 47(2), 422–441. <https://doi.org/10.1177/0309524x221124031>
39. Cheng, G., Lin, Y., Abur, A., Gómez-Expósito, A., & Wu, W. (2024). A survey of power system state estimation using multiple data sources: Pmus, SCADA, Ami, and beyond. *IEEE Transactions on Smart Grid*, 15(1), 1129–1151. <https://doi.org/10.1109/tsg.2023.3286401>
40. Shrestha, M., Johansen, C., Noll, J., & Roverso, D. (2020). A methodology for security classification applied to Smart Grid Infrastructures. *International Journal of Critical Infrastructure Protection*, 28, 100342. <https://doi.org/10.1016/j.ijcip.2020.100342>
41. Amović, M., Govedarica, M., Radulović, A., & Janković, I. (2021). Big Data in smart city: Management challenges. *Applied Sciences*, 11(10), 4557. <https://doi.org/10.3390/app11104557>
42. Güçyetmez, M., & Farhan, H. S. (2023). Enhancing smart grids with a new IOT and cloud-based smart meter to predict the energy consumption with time series. *Alexandria Engineering Journal*, 79, 44–55. <https://doi.org/10.1016/j.aej.2023.07.071>
43. Schulz, D., Lawanson, T., Ravikumar, K., & Cecchi, V. (2020). Loss estimation and visualization in distribution systems using AMI and Recloser Data. 2020 IEEE/PES Transmission and Distribution Conference and Exposition (T&D). <https://doi.org/10.1109/td39804.2020.9299891>
44. Deng, B., Wen, Y., & Yuan, P. (2020). Hybrid short-term load forecasting using the Hadoop MapReduce framework. 2020 IEEE Power & Energy Society General Meeting (PESGM). <https://doi.org/10.1109/pesgm41954.2020.9282094>
45. Hu, L., Zhang, L., Wang, T., & Li, K. (2020). Short-term load forecasting based on support vector regression considering cooling load in summer. 2020 Chinese Control And Decision Conference (CCDC). <https://doi.org/10.1109/ccdc49329.2020.9164387>
46. Banik, S., Saha, S. K., Banik, T., & Hossain, S. M. (2023). Anomaly detection techniques in Smart Grid Systems: A Review. 2023 IEEE World AI IoT Congress (AIoT). <https://doi.org/10.1109/aiiot58121.2023.10174485>
47. Ibrahim, M. I., Abdelfattah, S., Mahmoud, M., & Alasmary, W. (2021). Detecting electricity theft cyber-attacks in Cat Ami System using machine learning. 2021 International Symposium on Networks, Computers and Communications (ISNCC). <https://doi.org/10.1109/isncc52172.2021.9615629>
48. Takiddin, A., Ismail, M., Zafar, U., & Serpedin, E. (2021). Variational auto-encoder-based detection of electricity stealth cyber-attacks in Ami Networks. 2020 28th European Signal Processing Conference (EUSIPCO). <https://doi.org/10.23919/eusipco47968.2020.9287764>
49. Qi, R., Zheng, J., Luo, Z., & Li, Q. (2022). A novel unsupervised data-driven method for electricity theft detection in Ami using observer meters. *IEEE Transactions on Instrumentation and Measurement*, 71, 1–10. <https://doi.org/10.1109/tim.2022.3189748>

50. M Jahid Hasan, A. S., Rahman, M. S., Islam, M. S., & Yusuf, J. (2023). Data Driven Energy theft localization in a distribution network. 2023 International Conference on Information and Communication Technology for Sustainable Development (ICICT4SD). <https://doi.org/10.1109/iciict4sd59951.2023.10303520>

## АНАЛІЗ ПІДХОДІВ ДО ОПРАЦЮВАННЯ ВЕЛИКИХ ОБСЯГІВ ДАНИХ У РЕЖИМІ РЕАЛЬНОГО ЧАСУ У ВИМІРЮВАЛЬНІЙ ІНФРАСТРУКТУРІ

Роман Моравський<sup>1</sup>, Євгенія Левус<sup>2</sup>

Національний університет “Львівська політехніка”,  
кафедра програмного забезпечення, Львів, Україна

<sup>1</sup> E-mail: roman.o.moravskyi@lpnu.ua, ORCID: 0000-0002-6695-1920

<sup>2</sup> E-mail: yevheniia.v.levus@lpnu.ua, ORCID: 0000-0001-5109-7533

© Моравський Р., Левус Є., 2024

Інтелектуальні енергосистеми та комунікаційні технології, такі як передова вимірювальна інфраструктура (Advanced Metering Infrastructure, AMI), здійснили революцію в управлінні та моніторингу комунальних послуг. AMI використовує “розумні” лічильники (Smart Meter, SM), оснащені розширеними комунікаційними можливостями, що полегшує двосторонній зв’язок між комунальними підприємствами та споживачами. Отже, існує потреба в ефективних рішеннях для опрацювання даних у режимі реального часу, оскільки відомі підходи можуть не відповідати раніше встановленим угодам про рівень обслуговування (SLA) щодо показників продуктивності, точності та масштабованості. Метою цього дослідження є детальний огляд останніх публікацій, що стосуються методів розподіленої обробки даних в реальному часі для застосування в інтелектуальних вимірювальних мережах, а також виявлення проблем для подальших досліджень. Зокрема, це дослідження заглиблюється в ефективність і застосування розглянутих підходів в управлінні постійним потоком даних від розумних лічильників та пристроїв Інтернету Речей. Це дослідження має на меті визначити проблеми та перспективи опрацювання даних у реальному часі для інфраструктури інтелектуальних мереж, зосереджуючись на вирішенні складнощів опрацювання, управління та зберігання великих обсягів даних у реальному часі. Огляд літератури виявив дві основні сфери застосування опрацювання даних у реальному часі: оптимізація продуктивності потокового передавання даних та аналіз даних. Аналіз охоплює різні дослідження, кожне з яких представляє окремі методології та технології, що застосовують для вирішення проблем опрацювання великих обсягів даних у реальному часі від розумних лічильників та пристроїв Інтернету Речей. Майбутні дослідження повинні бути спрямовані на вирішення проблем та подолання обмежень, виявлених у цьому дослідженні.

**Ключові слова:** розподілена обробка в реальному часі; потік даних; розумна мережа; розумний лічильник; Передова вимірювальна інфраструктура.