

Pavlo Denysyuk¹, Mykhaylo Melnyk², Andriy Kernytskyy³, Denys Fizer⁴

¹ Computer Design Systems Department, Lviv Polytechnic National University, S. Bandery street 12, Lviv, Ukraine, E-mail: pavlo.y.denysiuk@lpnu.ua, ORCID 0000-0001-6544-0128

² Computer Design Systems Department, Lviv Polytechnic National University, S. Bandery street 12, Lviv, Ukraine, E-mail: Mykhaylo.R.Melnyk@lpnu.ua, ORCID 0000-0002-8593-8799

³ Computer Design Systems Department, Lviv Polytechnic National University, S. Bandery street 12, Lviv, Ukraine, E-mail: andriy.b.kernytskyy@lpnu.ua, 0000-0001-8188-559X

⁴ Computer Design Systems Department, Lviv Polytechnic National University, S. Bandery street 12, Lviv, Ukraine, E-mail: denys.fizer.mknit.2023@lpnu.ua

METHOD FOR RECONSTRUCTING 3D MODELS FROM IMAGES: A CASE STUDY USING THE SHAHED 136 DRONE

Received: November 04, 2024 / Revised: November 20, 2024 / Accepted: November 25, 2024

© Denysyuk P., Melnyk M., Kernytskyy A., Fizer D. 2024

<https://doi.org/>

Abstract. Method for reconstructing 3D models from images: a case study using the Shahed 136 drone. A study of the dimensional and proportional characteristics of the model is carried out. The main stages of model construction are considered. A block diagram of the image perspective transformation program is presented. The activity diagram given in the paper visualizes the steps required to perform an image transformation, including point selection, calculation, and generation of the final image. The proposed approach of image detection and using base points made it possible to obtain a model of the object. 3D modeling allowed for the effective application of reverse engineering, expanding the capabilities and improving the understanding of the complex aspects of the Shahed 136 drone design.

Keywords. Design, modelling, reverse engineering, research, Shahed 136, simulation, object, Fusion 360.

Introduction and Problem Statement

In the world of modern technology, where speed and accuracy are crucial factors, reverse engineering has become an important tool for understanding and improving existing technological solutions. Reverse engineering, the process of analyzing an object to identify its structural foundations and functionality without access to the original documents, opens up opportunities for innovation in various industries, including mechanical engineering, software, and biomedicine [1-2].

The latest research in reverse engineering focuses on the development of methods and technologies that allow for more accurate and faster analysis and reproduction of objects. One of the areas is the automation of reverse engineering processes using modern digital tools such as 3D modeling and computer vision.

Recreating 3D models from images is one of the most advanced areas of research in reverse engineering [3]. This method involves the use of transformation algorithms and analysis of image basepoints to create accurate three-dimensional models of objects. This approach allows us to study the physical properties of objects in detail, which is especially important when real access to objects is limited or impossible.

The relevance of developing and improving reverse engineering methods is growing, as these methods allow engineers and designers to understand and analyze existing devices and equipment quickly and efficiently, especially in the defense sector, where the speed of development and innovation is critical. Reverse engineering can be used to [4]:

1. Studying the designs and systems of competitors or enemies, allows you to understand their technical solutions and possible vulnerabilities.
2. Improving your own developments by analyzing existing technologies and improving the foundations based on them.
3. Creating accurate 3D models for simulations and testing, which significantly reduces the time for developing new equipment.
4. Effective adaptation of captured or purchased equipment samples for study and further use in the development of own projects.

In addition, thanks to 3D modeling, engineers can quickly create prototypes of new robotic vehicles, drones, armored vehicles, and other types of weapons. This makes it possible to test their effectiveness in different conditions without the need to physically produce each new idea, reducing the time and cost of research and design. In the field of military drone design, 3D modeling plays a critical role in the development, production, and improvement of unmanned aerial vehicles (UAVs), which have become an integral tool of modern armed forces. The use of three-dimensional modeling at the UAV design stage allows developers to thoroughly analyze the aerodynamic and structural characteristics of the vehicle. That is why works on the development and research of UAVs are relevant. In this paper, we propose to use the Shahed 136[5] as a basic UAV and design its 3D model. The proposed model will improve the understanding of the design features and analyze its physical and aerodynamic characteristics. In addition, the study and simulations will allow us to investigate and predict the behavior of the drone in different weather conditions.

This paper is devoted to the development and study of a virtual three-dimensional model of the Iranian-made Shahed 136 barrage munition. The relevance of the study is due to the widespread use of Shahed 136 in modern military conflicts, due to its low cost, simplicity of design, and significant destructive potential [6].

This study allows us to understand the main characteristics of the drone and its dimensions. Also, open sources describe the shape of the delta wing, which ensures flight stability and predictability compared to traditional configurations. This is especially important for drones with minimal automatic control systems [7-9]. Having analyzed and studied perspective transformation algorithms [10-13], it is possible to use the proposed approach in software implementation. An example of perspective change is shown in Figure 1.

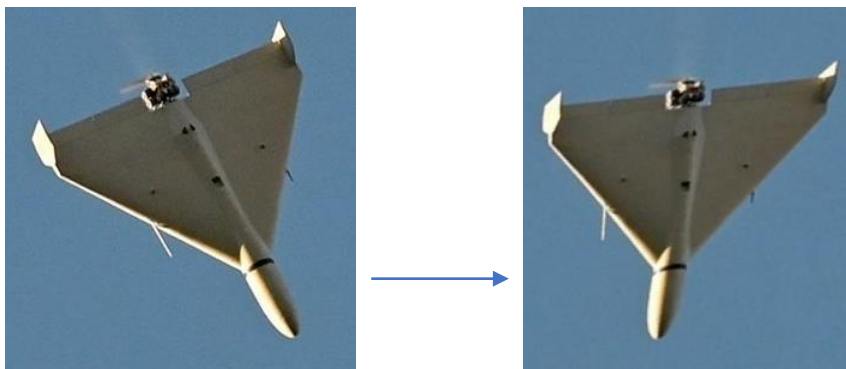

Fig.1. The result of a change in perspective

The main 3D modelling programmers are the following: Autodesk Fusion 360 [14], Autodesk Inventor and Solidworks. Their advantages are ease of use, power of modelling tools, integration with other applications, availability of specialized tools for different industries, simulation and analysis capabilities, documentation, size of the user community and affordability. Fusion 360 was chosen for the modelling due to its ease of use, powerful modelling tools and affordability.

Main Material Presentation

A software solution was developed to process the image by changing the perspective. An image transformation algorithm was developed that works by parsing the image and selecting 4 desired points,

after which a matrix equation with 8 unknowns is solved using the Gaussian method, and as a result, we get the desired image, the algorithm is shown in more detail in Figure 2.

It is also worth mentioning that not all images are amenable to and need to be transformed. To do this, the image must meet several criteria.

- The image must contain an obvious perspective deviation
- High enough quality of the input image for correct calculation and clear result of image alteration
- The perspective can be repeated or described by a quadrilateral, i.e. the simpler the geometric shape in the photo and the closer it is to the quadrilateral, the better the transformation can be performed.
- Absence of strong noise and light sources in the background, as they will prevent you from clearly selecting points for image transformation.

So, after analyzing all the input requirements, you can move on to implementation.

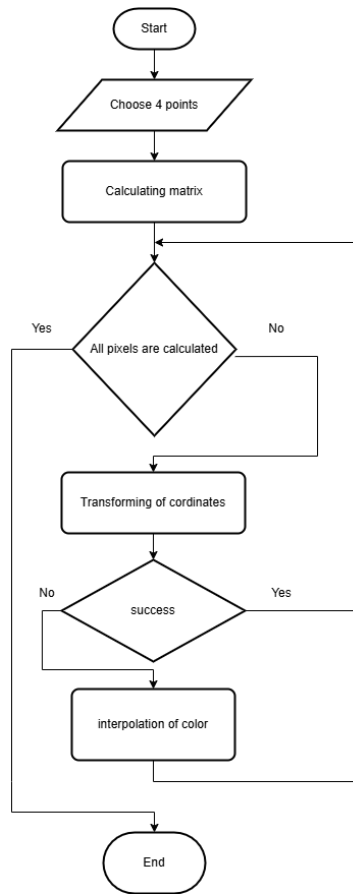

Fig. 2. Image transformation flowchart

The main step is to calculate the perspective transformation matrix. To do this, a system of linear equations was solved using the Gaussian method (Figure 3), using the four points of the source image and the four points of the target image as input. The resulting matrix is used to convert the pixel coordinates. Another important function is the one that applies the transformation matrix to the image. It creates a new image and converts the coordinates of each pixel of the original image using the conversion matrix. To smooth the result, bilinear interpolation is used, which allows for smoother transitions between pixel colors. Don't forget about the functionality that converts images to a format acceptable for display in Tkinter. It creates a PIL image, fills it with pixels, and converts it into an ImageTk.PhotoImage object that can be used with Tkinter elements.

It is also worth mentioning the function responsible for loading an image from a file. It uses the Pillow library (PIL) to open the image and converts it to RGB format, if necessary. This is important

because the entire code is designed to work with RGB images. The function also preserves the dimensions of the image and converts it into a pixel matrix that is convenient for further processing.

To understand all the processes during the application execution, UML diagrams were created, namely a class diagram and an activity diagram. Figure 3 shows the structural organisation of the software solution for image transformation in the form of a class diagram. This allows you to correctly understand the process of selecting points, parsing images, and performing matrix calculations using the Gaussian method. The activity diagram (Figure 5) allows to visualise the steps required to perform an image transformation, including point selection, calculation and generation of the final image. This diagram includes the conditions and constraints that must be met before an image can be transformed, providing a better understanding of the image suitability criteria for such processing.

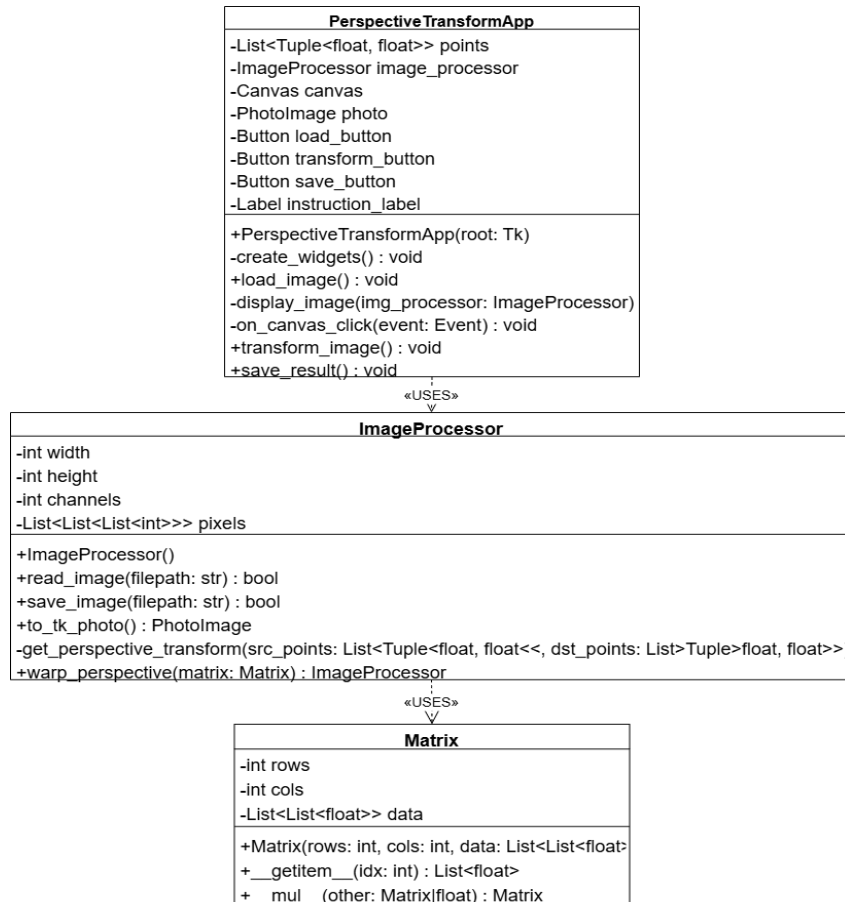

Fig. 3. Class diagram of the software solution

To begin designing, it is necessary to download and process several images. Let's start by processing the image (Figure 4), which clearly displays the defined dimensions.



Fig.4. Processed images.

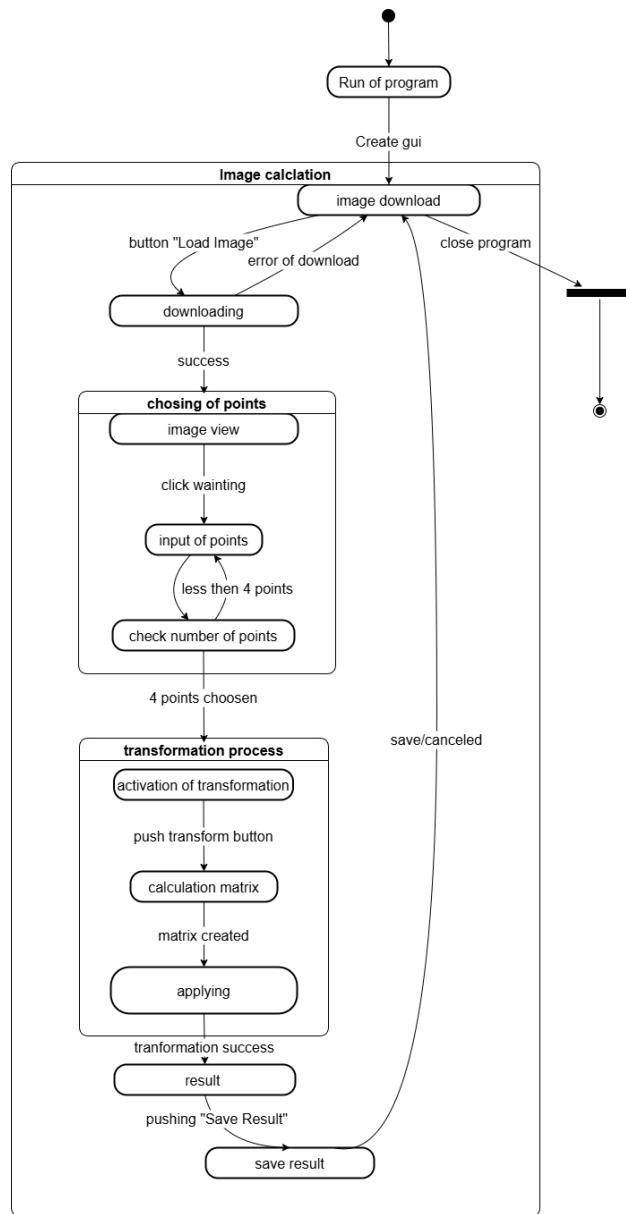

Fig. 5. Diagram of activities during image transformation

The result of the processed images is a 3D model that is used for further assembly (Figure 6):

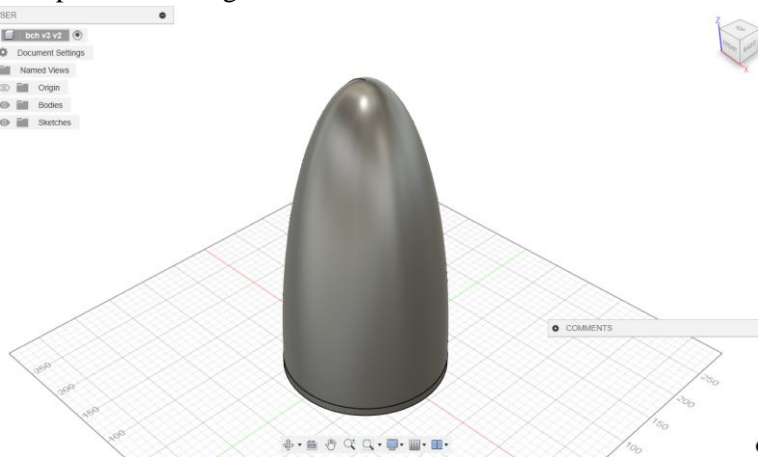

Fig 6. A designed part in Fusion 360.

To design the wing, basic dimensions were utilized, similar to the approach in the previous study. Reference dimensions for the drone, often available in the public domain, suggest a length of approximately 3 meters and a width of about 2.5 meters. However, these dimensions are not entirely reliable and can vary significantly depending on the specific version of the drone.

The most effective strategy involves determining the size of the wing projection at the attachment point to the nacelle and the overall wing width. The process begins by identifying the wing's width through analysis of the corresponding images. The next step is to determine the size of the projection, which will also involve examining the processed images.



Fig.7. Processed images to determine the wing projection

The obtained dimensions from the processed images will enable the design of a wing (Figure 8).

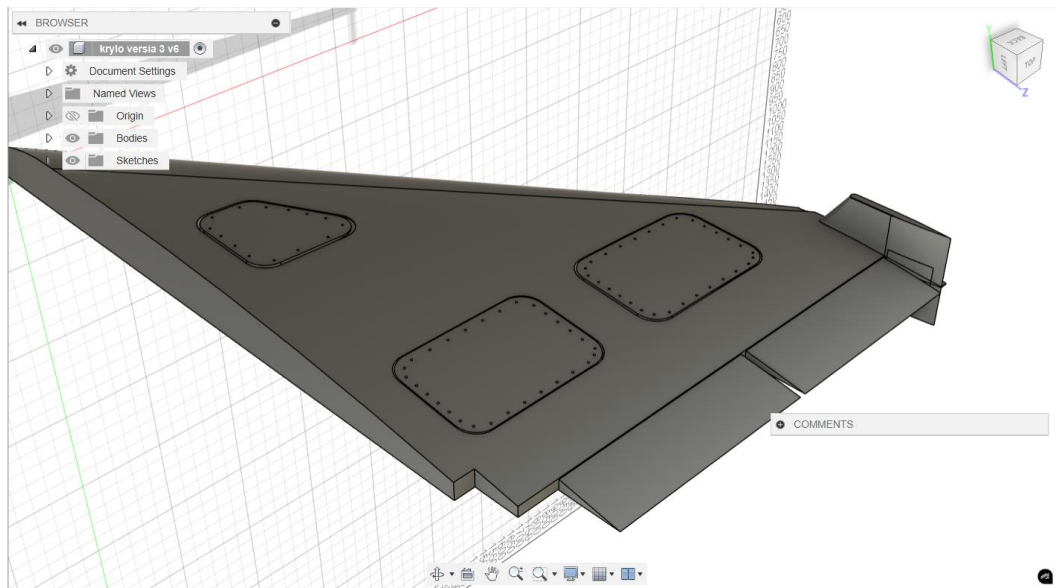

Fig.8. The designed wing of the drone

In this context, the nacelle serves as the structural component of the hull, providing attachment points for the wings, combat unit, and engine. Its dimensions, which are challenging to determine through image analysis, can be calculated analytically using the dimensions of adjacent, pre-designed elements.

The diameter of the nacelle can be derived from the diameter of the warhead, while its length is determined by the size of the wing. The nacelle's length should be shorter than the wing to allow space for the engine to be mounted at one end.

To ensure proper wing attachment, the wing shape must be recreated and slightly trimmed at the end to match the length of the engine nacelle, facilitating secure attachment. This sketch will serve as a copy of the wing projection (Figure 9).

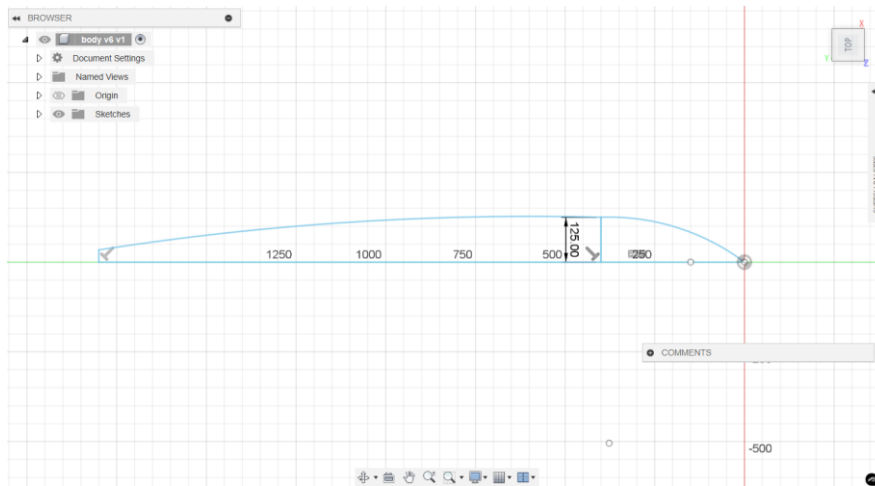

Fig. 9. Sketch of the wing projection on the engine nacelle

Next, the projection for wing attachment must be extracted in the same manner. The outcome of this step will be a designed nacelle, which will be used in the subsequent assembly process (Figure 10).

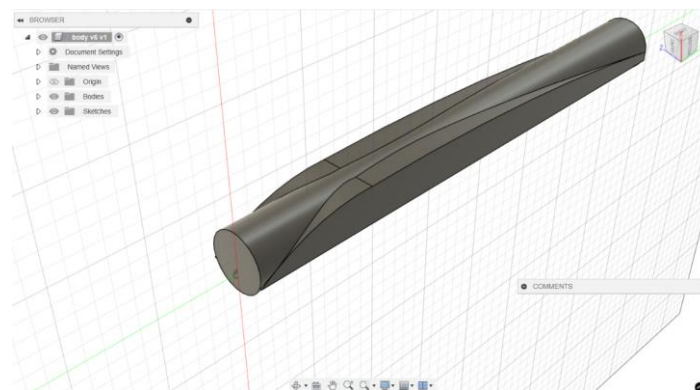

Fig. 10. Designed engine nacelle.

Results and discussion

As a result, all the models must be combined into an assembly to create a complete model of the desired drone. Additional details, such as selecting colors and materials, should be added to produce a model that closely resembles the real object (Figure 11).

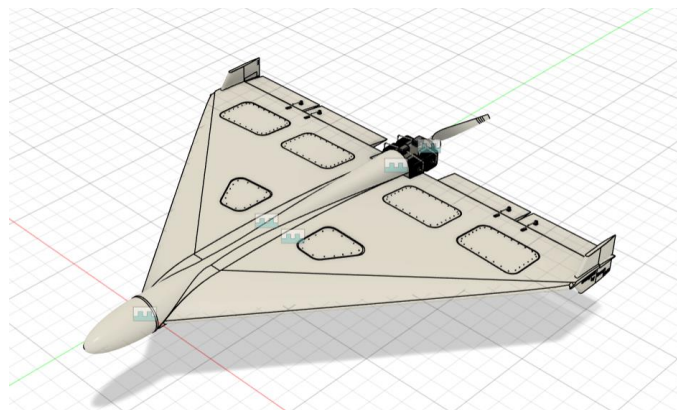

Fig. 11: The final assembly of the drone

This is the final model of the drone.(Figure 12)

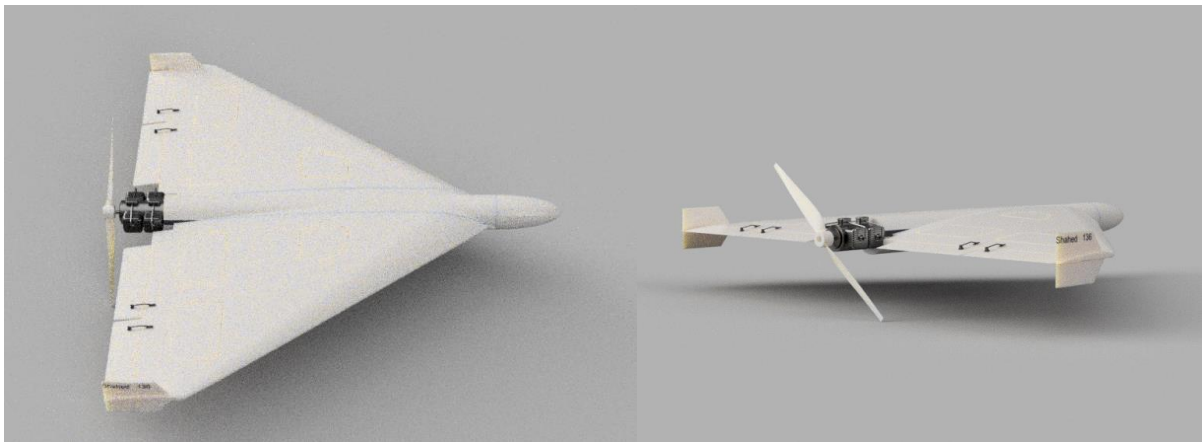

Fig. 12: Rendering result

In addition, the aerodynamic drag force was studied using Simscale and the created model. The result is displayed in the form of images of the drag force applied to certain parts of the drone.(Figure 13, 14)

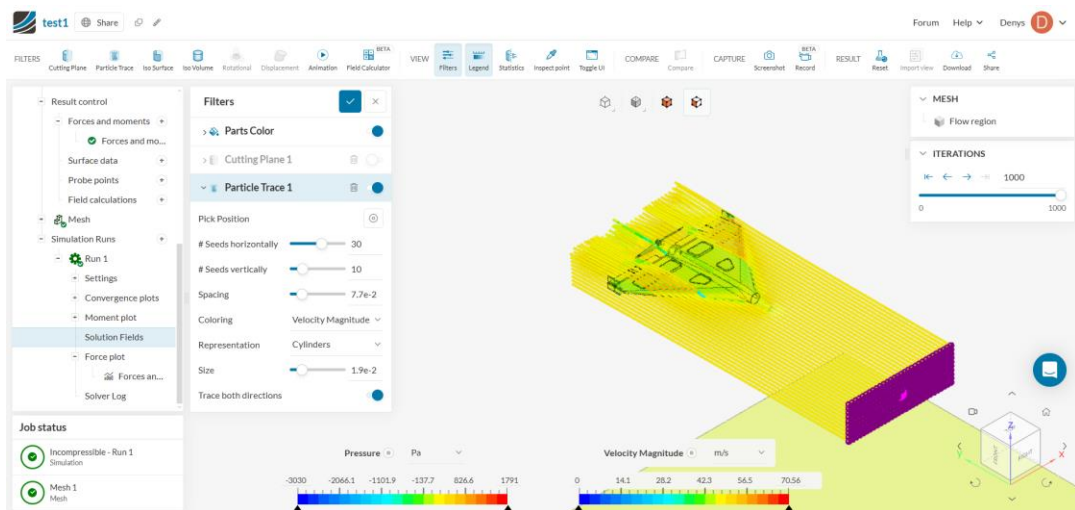

Fig. 13. Visualisation of air flow during the simulation.

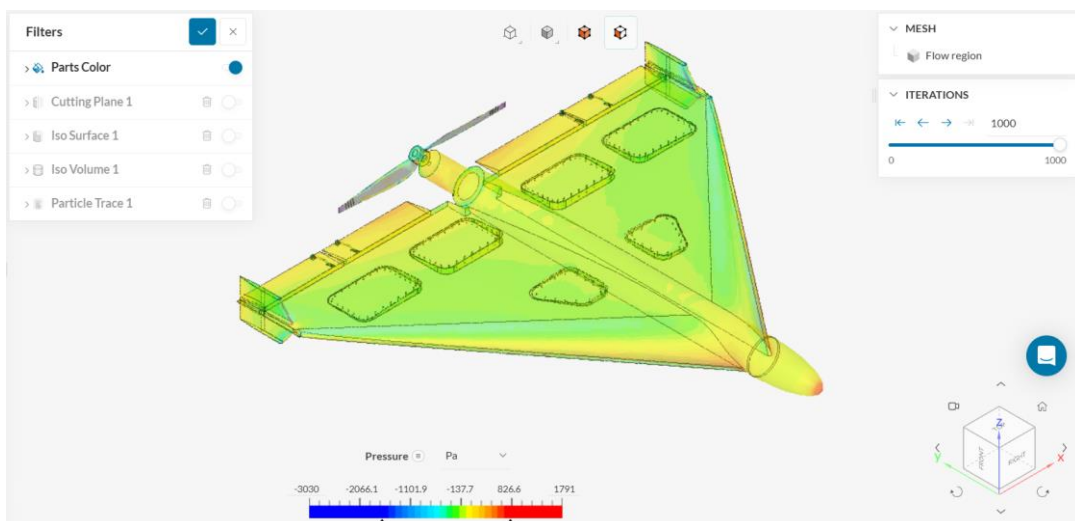

Fig. 14. Effect of air pressure on different parts of the drone

To automate the process, a model analysis application was developed for automated area calculation. The initial step involves solving the problem of automated area calculation. The .stl file format is ideal for this purpose, enabling relatively straightforward area calculations using the pyvista package to parse the file. The Metalprice API will serve as the API for tracking metal prices.

To fully understand the operation of the created solution, UML activity diagram was developed (Figure 15.) After loading all the models of the designed drone and specifying the thicknesses found. For the warhead it is 7 mm and for the rest of the body 5 mm, creating the material which need, after that program show the final cost of the Shahed 136 body. (Figure 16)

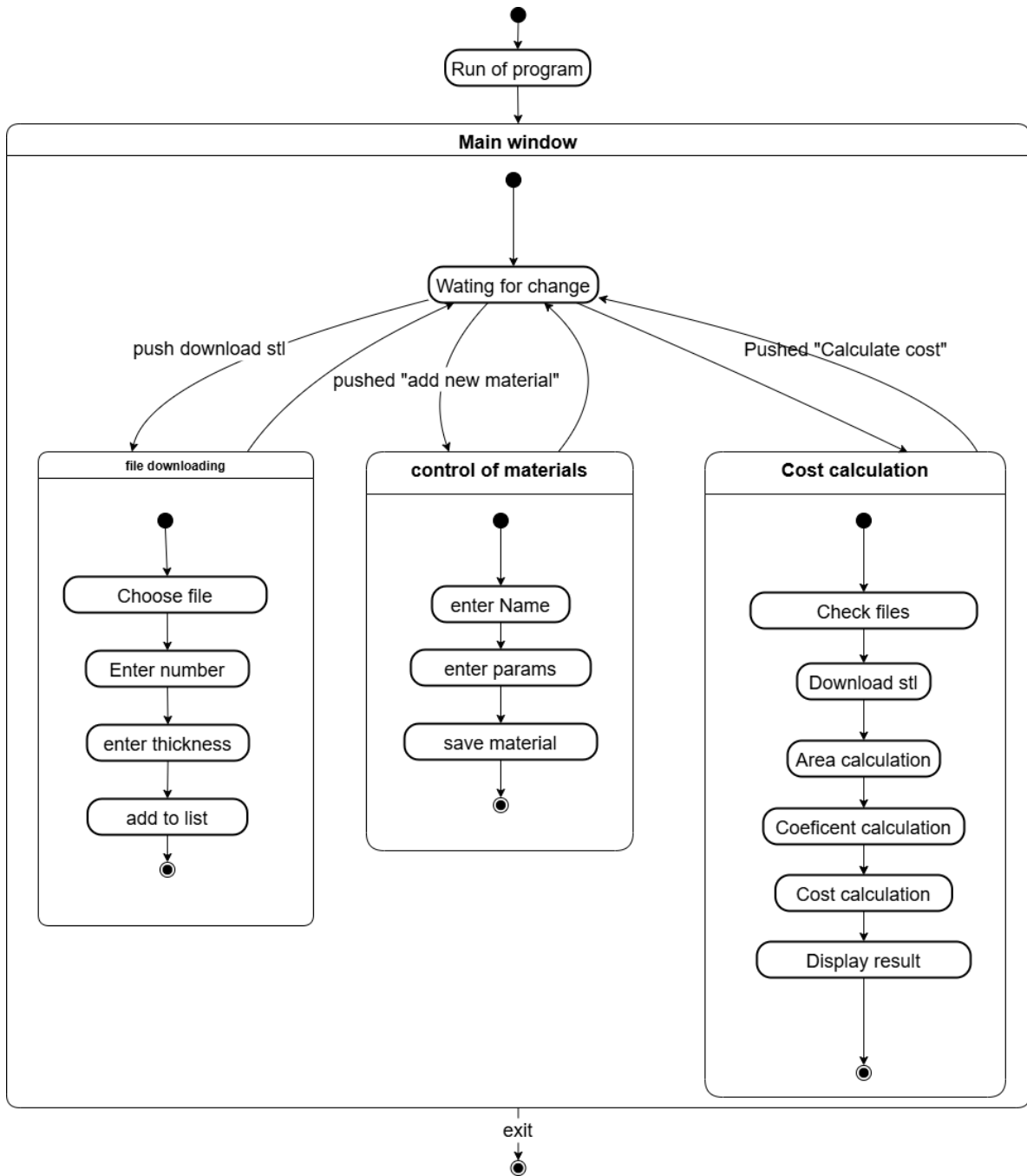

Fig. 15. Activity diagram

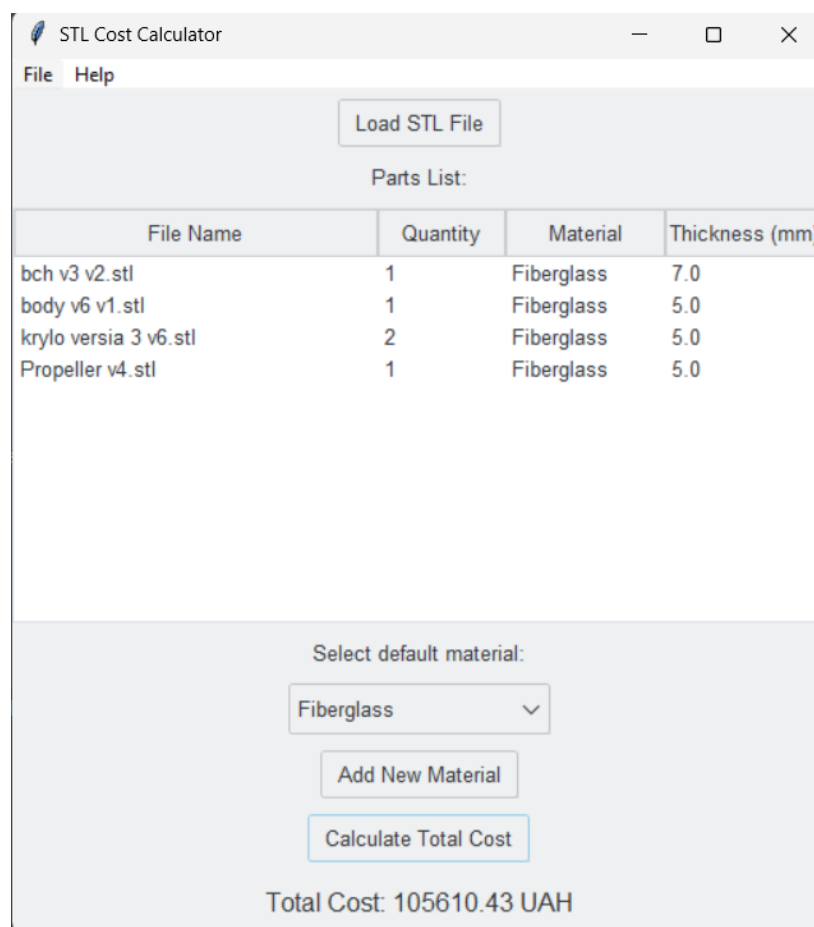

Fig. 16. The result of calculating the cost of the drone body

Conclusions

Analyzing the modeling results, it can be concluded that the Fusion 360 and Simscale systems fully allow for the development of the Shahed 136 3D model and its study. The development of the model was decomposed into the development of its components, such as the warhead, nacelle, and wings, which, when combined, provide a model of the object. The proposed approach of image detection and using base points made it possible to obtain a model of the object. 3D modeling allowed for the effective application of reverse engineering, expanding the capabilities and improving the understanding of the complex aspects of the Shahed 136 drone design.

References

- [1] Buonamici F., Carfagni M., Furferi R. et al., 2018, Reverse engineering modeling methods and tools: a survey, *Computer-Aided Design & Application*, 15(3), 443–464.
- [2] Kasapakis V., Gavalas D., Dzardanova E., 3D Modelling Through Photogrammetry in Cultural Heritage, *Encyclopedia of Computer Graphics and Games*, 2024, 23-26
- [3] Saini D., Inverse Reconstruction Methodologies: A Review, *Applications and Applied Mathematics: An International Journal (AAM)*, Volume 17, Issue 3 (2022) Special Issue No. 10 (October 2022), 31-46
- [4] Łukaszewicz A., Kernytskyy A., Melnyk M., Holovatyy A., Skorulski G., 2024, The role and development of CAx methods and tools in reverse engineering, *Collective monograph: CAD in Machinery Design Implementation and Educational Issues. XXXI International Conference*, Oficyna Wydawnicza Politechniki Białostockiej, Białystok, pp.224-232.
- [5] Shahed 136 URL:<https://w.wiki/98EW>
- [6] Strategic Evolution of Unmanned Aerial Systems: Analyzing the Shahed-136 and Global Drone Advancements URL:<https://www.researchgate.net/publication/384605039>

Method for Reconstructing 3D Models from Images: a Case Study Using the Shahed 136 Drone

- [7] “Cheaper Precision Weapons: An Exploratory Study about the HESA Shahed 136” Daniel Zampronha¹, Aline Albuquerque², 2024, с. 2-10.
- [8] Terror in the details: Western-made Components in Russia’s Shahed-136 Attacks. URL: https://www.iphronline.org/wp-content/uploads/2023/07/Report-drones-final_3.07.pdf
- [9] Strategic Analysis of the Shahed-136 UAV: Global Implications URL: <https://ragex.co/shahed-136-uav-analysis/>
- [10] Document Image Enhancement with Perspective Transformation using Python, Indra Bayu Muktyas¹, Nerru Pranuta Murnaka², Samsul Arifin³, Wikky Fawwaz Al Maki⁴. ^{1,2}STKIP Surya, Tangerang, Indonesia, ³Binus University, Jakarta, Indonesia, ⁴Telkom University, Bandung, Indonesia
- [11] Document Image Enhancement with Perspective Transformation using Python Indra Bayu Muktyas^{1,*}, Nerru Pranuta Murnaka¹, Samsul Arifin², Wikky Fawwaz Al Mak
- [12] Complete Scanning Application Using OpenCv Ayushe Gangal, Peeyush Kumar, Sunita Kumari
- [13] Perspective Transformation Data Augmentation for Object Detection Ke Wang, Bin Fang, Jiye Qian; Su Yang, Xin Zhou, Jie Zhou
- [14] Fusion 360 URL: <https://www.autodesk.com/products/fusion-360/personal>

Павло Денисюк¹, Михайло Мельник², Андрій Керницький³, Денис Фізер⁴

¹ Кафедра систем автоматизованого проектування, Національний університет Львівська політехніка, вул. С. Бандери 12, Львів, Україна, E-mail: pavlo.y.denysiuk@lpnu.ua, ORCID 0000-0001-6544-0128

² Кафедра систем автоматизованого проектування, Національний університет Львівська політехніка, вул. С. Бандери 12, Львів, Україна, E-mail: Mukhaylo.R.Melnyk@lpnu.ua, ORCID 0000-0002-8593-8799

³ Кафедра систем автоматизованого проектування, Національний університет Львівська політехніка, вул. С. Бандери 12, Львів, Україна, E-mail: andriy.b.kernytskyu@lpnu.ua, 0000-0001-8188-559X

⁴ Кафедра систем автоматизованого проектування, Національний університет Львівська політехніка, вул. С. Бандери 12, Львів, Україна, E-mail: denys.fizer.mknit.2023@lpnu.ua

МЕТОД РЕКОНСТРУКЦІЇ 3D МОДЕЛЕЙ ЗА ЗОБРАЖЕННЯМИ: ПРИКЛАД З ВИКОРИСТАННЯ ДРОНУ SHAHED 136

Отримано: Листопад 04, 2024 / Переглянуто: Листопад 20, 2024 / Прийнято: Листопад 25, 2024

© Денисюк П., Мельник М., Керницький А., Фізер Д., 2024

Анотація. В статті описано метод реконструкції 3D-моделей із зображень: кейс з використанням дрона Shahed 136. Проведено дослідження розмірно-пропорційних характеристик моделі. Розглянуто основні етапи побудови моделі. Наведено структурну схему програми трансформації перспективи зображення. Діаграма, наведена в статті, візуалізує кроки, необхідні для виконання трансформації зображення, включаючи вибір точки, обчислення та створення остаточного зображення. Запропонований підхід визначення зображення та використання базових точок дозволив отримати модель об’єкта. 3D-моделювання дозволило ефективно застосувати зворотне проектування, розширивши можливості та покращивши розуміння складних аспектів конструкції безпілотної Shahed 136.

Ключові слова: Проектування, моделювання, зворотне проектування, дослідження, Shahed 136, моделювання, об’єкт, Fusion 360.