

ENABLING SMART SPECTROSCOPY VIA ARDUINO IoT CLOUD

*Andriy Krupych, Pavlo Levush**Ivan Franko National University of Lviv, 1, Universytetska str., Lviv, 79000, Ukraine**Authors' e-mails: andriy.krupych@lnu.edu.ua, pavlo.levush@lnu.edu.ua*<https://doi.org/10.23939/acps2025.01.041>

Submitted on 14.04.2025

© Krupych A., Levush P., 2025

Abstract: This work presents a cloud-integrated IoT system for the real-time control and spectral monitoring of tunable light sources. Leveraging the Arduino IoT Cloud platform, the system has established bidirectional communication via the MQTT protocol to manage individual color channels of a programmable light source. Spectral data has been captured using a StellarNet spectrometer and transmitted over to the Arduino IoT Cloud, enabling live visualization and feedback control on the cloud dashboard. This closed-loop architecture has facilitated precise spectral tuning based on user-defined input or automated routines, making it suitable for applications in photonics research and material characterization. The platform has demonstrated flexibility, remote accessibility, and modular integration of commercial spectrometers with cloud-based control interfaces.

Index terms: IoT Concepts, Information Technology Cloud-based Spectroscopy, MQTT Communication, IoT Light Source Control.

I. INTRODUCTION

The integration of Internet of Things (IoT) technologies with cloud platforms is transforming how laboratory instrumentation and experiments are accessed and controlled. Leveraging lightweight protocols such as MQTT (Message Queuing Telemetry Transport), IoT systems can enable real-time data exchange between physical devices and cloud dashboards. This allows laboratories to be reimagined as remotely accessible, cloud-controlled environments, suitable for both educational and research applications.

MQTT-based cloud infrastructures have already demonstrated high utility across various domains. For instance, secure MQTT implementations for distributed measurement systems have proven effective in managing constrained IoT hardware with real-time feedback [1]. Additionally, cloud-integrated agricultural monitoring systems highlight how MQTT can support efficient data routing and secure updates across spatially distributed devices [2].

More advanced applications have included real-time instrumentation feedback, such as radiation detection systems that synchronize physical sensors with event-based cloud visualizations [3]. Similar strategies are being applied in industrial diagnostics, where RGB representations of time-frequency data from vibration sensors are transmitted to the cloud for condition monitoring [4].

However, few implementations offer closed-loop systems that couple user-actuated light sources with real-time spectral measurement, integrated fully with cloud dashboards. Some IoT-augmented environments address remote device interaction but often fall short in providing synchronized visual feedback derived from spectroscopy [5].

This paper presents a functional prototype of a remote laboratory system that overcomes these limitations by combining an RGB light source, a StellarNet spectrometer, and a Latte Panda single-board computer (SBC) control unit, all integrated with Arduino Cloud. The setup enables real-time remote control and live spectral data visualization, establishing a bidirectional, cloud-driven feedback system for remote experimentation.

II. LITERATURE REVIEW AND PROBLEM STATEMENT

Advances in Internet of Things (IoT) and cloud-connected scientific instrumentation have enabled new forms of remote laboratory systems that facilitate experimentation, monitoring, and control beyond the physical lab environment. These architectures frequently utilize lightweight communication protocols, particularly MQTT, to link devices to cloud dashboards for data collection and command execution in near real time.

Low-cost spectrometers and optical sensors have become a key part of this transformation. Several studies have demonstrated the feasibility of portable, cloud-connected spectral acquisition systems. For instance, open-source platforms for multi-spectral sensing and hyperspectral analysis have been developed to work with IoT platforms, showcasing the viability of using MQTT to stream measurement data to remote users [6-8]. These systems enable high-frequency, continuous sampling of optical data for indoor and outdoor environments.

Parallel research has emphasized the remote management of laboratory instruments, such as optical spectrometers and microscopes, via cloud services. Remote access platforms that integrate with services like AWS or local servers offer real-time control, automation, and logging, making them particularly attractive for both teaching and research purposes [9-11]. Others have focused on cloud-driven setups for glyphosate residue detection, COVID-19 monitoring, and two-photon microscopy, demonstrating how MQTT-based systems can

serve highly specific scientific domains with strong performance and low latency [12,13].

Several experimental platforms have also addressed the need for remote laboratory teaching tools. These include the use of augmented reality interfaces, virtual IoT labs, and smart lab systems that rely on MQTT to manage bidirectional data flows between cloud dashboards and lab devices [14-16]. Examples include Talk2Lab – a framework that enables smart laboratory interaction – and remote MQTT-based learning environments designed for applied science curricula [17-19].

Despite these developments, most existing systems focus on either sensor data acquisition or actuation control in isolation. Very few offer a closed-loop feedback system that combines both: allowing users to remotely modify an optical signal (e.g., RGB light source) and immediately observe its spectral effect via integrated cloud dashboards. Moreover, many platforms lack general-purpose flexibility, being tailored for specific applications rather than enabling modular reuse across diverse experiments.

Although MQTT-based architectures and cloud interfaces are increasingly used in remote labs, a gap remains in fully integrated systems that combine real-time control of light sources, cloud synchronization of measurements and usage of modern, flexible tools.

Most platforms reviewed provide partial implementations – focused either on monitoring or control – but do not offer a unified architecture that allows closed-loop experimentation through a cloud interface. Furthermore, real-time spectral visualization remains limited on many cloud dashboards, which often lack support for full spectral plots and instead rely on simplified metrics.

This project addresses these limitations by proposing a cloud-controlled remote laboratory platform that integrates: RGB light source control via Arduino IoT Cloud, spectral feedback from a StellarNet spectrometer, real-time MQTT data exchange, and a modular software framework that supports further extensions. By combining these components, the system offers a practical model for remotely accessible, feedback-driven scientific experimentation.

III. SCOPE OF WORK AND OBJECTIVES

This project focuses on the development and deployment of a modular, remotely accessible light control and spectral monitoring system, built around a SBC serving as the central node. The SBC runs a custom script that interfaces three key components: an RGB light source, adjustable via MQTT-based control, a StellarNet spectrometer, used to acquire spectral data from the light source, and the Arduino Cloud platform, which provides a user-facing dashboard for both control (RGB tuning) and visualization (real-time spectral plots).

The system architecture enables full bidirectional communication: users can adjust light parameters through the cloud dashboard, and the resulting spectral response is measured and sent back for live display. The use of MQTT ensures efficient, low-latency messaging between the SBC and the cloud infrastructure.

While the current implementation supports a tunable light source and a spectrometer, the design is inherently extensible. The SBC can be configured to support additional IoT devices, enabling modular expansion depending on future requirements. This system can serve as a remote-access laboratory showcase, facilitating experimentation, demonstrations, and remote learning through a web interface.

The primary objectives of this work are as follows: develop a flexible IoT-enabled platform that integrates cloud control and spectral sensing into a unified system accessible via the web; enable real-time remote control of a light source and synchronized spectral feedback through a user-friendly cloud dashboard; demonstrate modular extensibility, showing that the platform can be expanded with additional sensors or actuators on demand; support remote scientific experimentation and demonstration, especially in educational or collaborative research contexts, by offering a cloud-based, low-cost, and portable setup.

By addressing these objectives, the project lays the groundwork for an adaptive, real-time, IoT-enabled spectroscopy control system suitable for modern laboratory automation and cloud-based experimentation.

IV. IMPLEMENTATION OF A CLOUD-CONTROLLED SPECTROSCOPY PLATFORM

The system is designed as a remote laboratory framework that integrates physical light-control and measurement devices with cloud-based interfaces via an IoT-enabled architecture (Fig. 1).

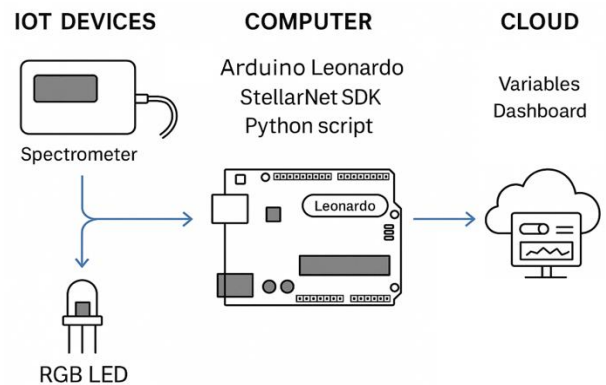

Fig. 1. Overall system architecture

At the device layer, a tunable light source (connected RGB LED) and a StellarNet spectrometer serve as the primary hardware components. These are connected to a Latte Panda SBC, which hosts both the Arduino Leonardo microcontroller (to control the LED) and the StellarNet SDK (to communicate with the spectrometer). A Python script bridges the hardware with the cloud: it subscribes to control variables via MQTT from the Arduino IoT Cloud, actuates the LED via GPIO outputs, reads spectral data from the spectrometer, and publishes the processed RGB peak values back to the cloud. The cloud interface features a real-time dashboard for bidirectional interaction,

enabling remote users to both control the light source and observe the spectral feedback through a web-accessible interface.

This closed-loop configuration allows the system to function as a scalable, web-controlled experimental demonstration platform.

A. A COMPACT SPECTROMETER

The spectroscopic measurements in this system are carried out using the StellarNet Green-Wave Spectrometer, a compact, cost-effective device well-suited for portable and embedded optical analysis. This spectrometer supports USB connectivity for integration with host systems and provides a fiber optic input, enabling precise alignment with light sources in laboratory setups.

In this implementation, the fiber optic cable is positioned to receive light emitted from the RGB LED, allowing the spectrometer to capture the resulting emission spectrum with high fidelity. The spectrometer connects via USB to the Latte Panda single-board computer, where it is controlled using StellarNet's official Python SDK.

These tools not only identify vulnerabilities with precision but also provide valuable insights into how these weaknesses can be mitigated. With their ability to automate and enhance traditional penetration testing methods, AI tools are paving the way for a more robust, proactive approach to cybersecurity.

I. CHALLENGES AND LIMITATIONS OF AI IN PENETRATION TESTING

Despite the benefits AI-powered penetration testing tools offer in terms of efficiency and accuracy, their adoption comes with several challenges and limitations

that need to be carefully addressed.

A primary concern is the occurrence of false positives and false negatives. False positives can lead to unnecessary alerts and wasted resources when a non-existent vulnerability is flagged. False negatives, on the other hand, may leave critical security gaps unaddressed. Although AI systems are continually improving, human oversight remains essential to minimize these errors and ensure the reliability of results.

Another limitation is the over-reliance on automation. While AI excels in handling repetitive tasks and processing large datasets, it lacks the intuitive decision-making and contextual understanding that human testers provide. AI should therefore be viewed as a tool to augment, not replace, human expertise. Skilled professionals remain essential for nuanced analysis and decision-making in complex security scenarios.

B. LATTE PANDA STATION

At the core of the system lies the Latte Panda SBC, a unique development platform that combines a Windows-based computing environment with an embedded Arduino Leonardo microcontroller on a single device. This hybrid architecture makes Latte Panda ideal for IoT applications that require both hardware-level control (e.g., GPIO pin access via Arduino) and high-level data processing (e.g., spectral analysis in Python).

In this project, the Latte Panda serves as the main control unit, managing direct control of the RGB LED through the onboard Arduino Leonardo, performing spectral data acquisition via the USB-connected StellarNet spectrometer, and bidirectional communication with the Arduino IoT Cloud using MQTT protocol.

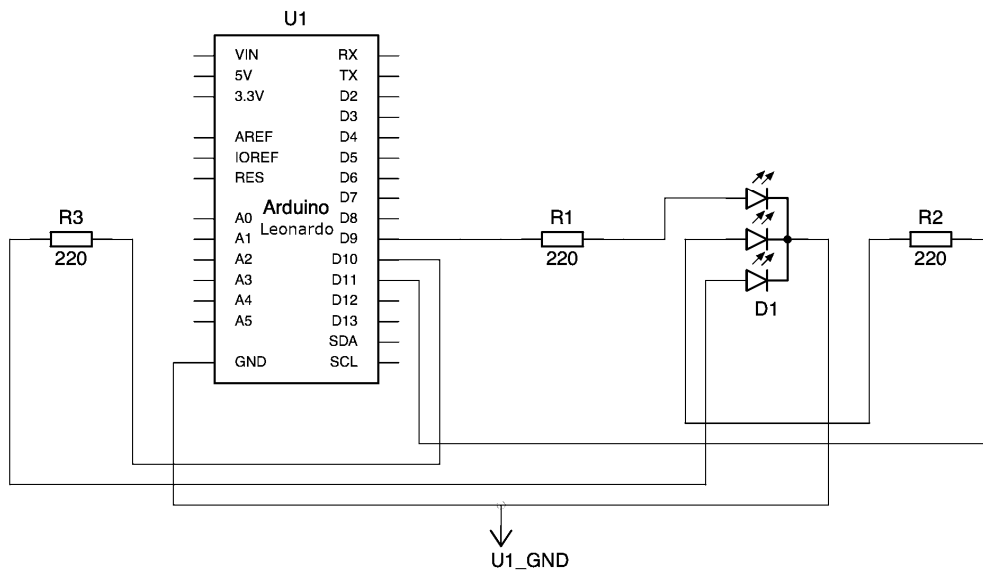

Fig. 2. Integrated Arduino Leonardo LED control circuit.

To run the system's integrated control and sensing script, Python (Version 3.7 or later) must be installed. A It is required to execute the main control script.

Python Libraries to install: pyFirmata – to communicate with the Arduino Leonardo for GPIO control; scipy – specifically `find_peaks()` for spectral signal processing; arduino-iot-cloud – for interacting with Arduino IoT Cloud via MQTT; stellarnet_driver3 – proprietary SDK provided by StellarNet for accessing and controlling the spectrometer.

C. CONTROL SCRIPT

At the heart of the system lies a unified Python control script that manages communication between the Arduino Leonardo, StellarNet spectrometer, and Arduino IoT Cloud. This script acts as a central coordinator, handling both hardware-level I/O operations and high-level cloud interactions.

The script is designed for continuous execution, enabling real-time bidirectional communication through three primary functional modules:

a. Cloud Communication via Arduino Cloud API

The script connects to the Arduino Cloud using the `arduino_iot_cloud` Python library and device credentials (`DEVICE_ID`, `SECRET_KEY`). It registers six cloud variables.

Three `toggle_*` Boolean variables with write access: these receive user input from the cloud dashboard and are linked to callback functions (`on_toggle_red`, `on_toggle_green`, `on_toggle_blue`) that control the respective LED channels.

Three RGB intensity float variables (`red`, `green`, `blue`): these are updated by the script based on spectral readings and serve as real-time feedback for the dashboard plot.

b. LED Control via pyFirmata

The script uses the `pyFirmata` library to interact with the Arduino Leonardo's digital pins (D9, D10, D11) from the Latte Panda. Each pin corresponds to one of the RGB LED channels. When a cloud variable is toggled, the associated callback function updates the pin's output state, turning the corresponding LED on or off (Fig. 3).



Fig. 3. Experimental setup with LED on

c. Spectrometer Interface and Signal Processing

Using the proprietary `stellarnet_driver3` SDK, the script initializes the StellarNet spectrometer, configures acquisition parameters (integration time, averaging, smoothing), and retrieves a spectrum every second.

A peak-finding algorithm (`scipy.signal.find_peaks`) scans the spectrum for intensity maxima within specified wavelength windows: Blue 450–485 nm, Green: 500–565 nm, Red: 625–750 nm. The highest value within each range is interpreted as the RGB intensity and pushed to the cloud (Fig. 4). If no peaks are found, the values default to zero.

D. ARDUINO IoT CLOUD

Arduino IoT Cloud is a cloud-based IoT platform that allows users to connect, monitor, and control hardware devices over the internet using a user-friendly web interface. Designed primarily for Arduino-compatible microcontrollers, it supports MQTT-based communication, secure cloud storage of variable data, and interactive dashboards for real-time control and visualization.

In this system, Arduino IoT Cloud acts as the central interface between the user and the physical devices (LED and spectrometer). It enables full bidirectional communication: users can remotely control the RGB LED channels, while receiving live spectral intensity feedback from the StellarNet spectrometer through cloud-synchronized variables.

The platform uses six cloud variables to support control and feedback. Boolean Variables `toggle_red`, `toggle_green`, `toggle_blue` (Read & Write) are used to control the state of each RGB channel. Float Variables `red`, `green`, `blue` (Write Only) store the intensity values measured by the spectrometer for the respective wavelength regions.

The script updates these values every second based on the dominant peaks identified in the spectrum.

Due to current limitations in Arduino IoT Cloud, real-time plotting of full spectral data (intensity vs. wavelength) is not supported. Instead, the system visualizes a simplified output by plotting the three RGB intensity values. This provides a useful approximation of the light composition while remaining compatible with the dashboard's time-series plot functionality.

A custom dashboard was created to enable intuitive remote interaction. Three toggle switches, each linked to one of the `toggle_*` Boolean variables, allowing users to turn the red, green, or blue LED channels on and off individually. A time-series plot widget displaying the red, green, and blue intensity values as they are updated from the spectrometer.

The dashboard updates once per second, synchronously with the main Python script's measurement loop. This ensures that user input and spectral output are reflected in near real time, enabling a live, interactive feedback loop between the cloud interface and the physical laboratory setup.



Fig. 4. Arduino Cloud Dashboard with all RGB channels on.

V. CONCLUSION

This work demonstrated a practical and extensible framework for implementing a remote laboratory environment by integrating physical hardware (light source and spectrometer) with cloud-based control and monitoring via Arduino IoT Cloud. The platform offered real-time bidirectional communication using MQTT, bridging the gap between laboratory-grade measurement tools and modern IoT infrastructure.

The broader implication of this work lies in its potential to serve as a blueprint for future remote laboratories. Such systems can empower distance education, facilitate shared access to specialized instruments, and reduce barriers in collaborative scientific research. Researchers may include additional IoT-enabled devices – such as motors for adjusting samples and filters, tunable LED arrays, laser modules, smart relays, etc. to create a full-scale remote laboratory.

Ultimately, this project not only showcases a functioning IoT-based spectroscopy system but also contributes to the growing body of work in digitally accessible science, highlighting how robust, cloud-integrated laboratory tools can be made available on demand from anywhere in the world.

VI. ACKNOWLEDGEMENT

We are grateful for the help organizing the experiment and continuous consultancy to Dr. Ivan Karbovnyk and Dr. Oleksii Kushnir.

References

- [1] Gentile, A. F., Macri, D., Carni, D. L., Greco, E., & Lamonaca, F. (2024). A Performance Analysis of Security Protocols for Distributed Measurement Systems Based on Internet of Things with Constrained Hardware and Open Source Infrastructures. *Sensors*, 24(9), 2781. DOI: <https://doi.org/10.3390/s24092781>
- [2] Has, M., Kreković, D., Kušek, M., & Podnar Žarko, I. (2024). Efficient Data Management in Agricultural IoT: Compression, Security, and MQTT Protocol Analysis. *Sensors*, 24(11), 3517. DOI: <https://doi.org/10.3390/s24113517>
- [3] Hernández-Gutiérrez, C. A., Delgado-del-Carpio, M., Zebadúa-Chavarría, L. A., Hernández-de-León, H. R., Escobar-Gómez, E. N., & Quevedo-López, M. (2023). IoT-Enabled System for Detection, Monitoring, and Tracking of Nuclear Materials. *Electronics*, 12(14), 3042. DOI: <https://doi.org/10.3390/electronics12143042>
- [4] Łuczak, D., Brock, S., & Siembab, K. (2023). Cloud Based Fault Diagnosis by Convolutional Neural Network as Time-Frequency RGB Image Recognition of Industrial Machine Vibration with Internet of Things Connectivity. *Sensors*, 23(7), 3755. DOI: <https://doi.org/10.3390/s23073755>
- [5] Stark, E., Kučera, E., Haffner, O., Drahoš, P., & Leskovský, R. (2020). Using Augmented Reality and Internet of Things for Control and Monitoring of Mechatronic Devices. *Electronics*, 9(8), 1272. DOI: <https://doi.org/10.3390/electronics9081272>
- [6] Baird, S. G. & Sparks, T. D. (2023). Building a “Hello World” for self-driving labs: The Closed-loop Spectroscopy Lab Light-mixing demo. *STAR Protocols*, 4(2), 102329. DOI: <https://doi.org/10.1016/j.xpro.2023.102329>
- [7] Kneifel, J., Roj, R., Woyand, H.-B., Theiß, R., & Dültgen, P. (2023). An IIoT-Device for Acquisition and Analysis of High-Frequency Data Processed by Artificial Intelligence. *IoT*, 4(3), 244-264. DOI: <https://doi.org/10.3390/iot4030013>
- [8] Botero-Valencia, J. S. & Valencia-Aguirre, J. (2021). Portable low-cost IoT hyperspectral acquisition device for indoor/outdoor applications. *HardwareX*, 10, e00216. DOI: <https://doi.org/10.1016/j.ohx.2021.e00216>
- [9] Taimun, T. Y., Sharan, M. I., Azad, A., & Joarder, M. I. (2025). Smart Maintenance and Reliability Engineering in Manufacturing. *Saudi J Eng Technol*, 10(4). DOI: <https://doi.org/10.36348/sjet.2025.v10i04.009>
- [10] Baudin, P. V., Ly, V. T., Pansodtee, P., Jung, E. A., Currie, R., Hoffman, R., Willsey, H. R., Pollen, A. A., Nowakowski, T. J., Haussler, D., Mostajo-Radji, M. A., Salama, S. R., & Teodorescu, M. (2022). Low cost cloud-based remote microscopy for biological sciences. *Internet*

- of Things, 18, 100454. DOI: <https://doi.org/10.1016/j.ijot.2021.100454>
- [11] Pissard, A., Marques, E. J. N., Dardenne, P., Lateur, M., Pasquini, C., Pimentel, M. F., Pierna, J. A. F., & Baeten, V. (2021). Evaluation of a handheld ultra-compact NIR spectrometer for rapid and non-destructive determination of apple fruit quality. *Postharvest Biology and Technology*, 172, 111375. DOI: <https://doi.org/10.1016/j.postharvbio.2020.111375>
- [12] Aira, J., Olivares, T., Delicado, F. M. (2022). SpectroGLY: A Low-Cost IoT-Based Ecosystem for the Detection of Glyphosate Residues in Waters. *IEEE Transactions on Instrumentation and Measurement*, vol. 71, 6005610. DOI: <https://doi.org/10.1109/TIM.2022.3196947>
- [13] Kadham, N.R., Krishna, P.G. & Ravi, K.S. (2025). IoT-Based Remote Monitoring as a Distance (Online) Laboratory for Applied Learning. *SN Computer Science*. 6, 114. DOI: <https://doi.org/10.1007/s42979-024-03649-9>
- [14] Adão, T., Pinho, T., Pádua, L., Magalhães, L. G., J. Sousa, J., & Peres, E. (2021). Prototyping IoT-Based Virtual Environments: An Approach toward the Sustainable Remote Management of Distributed Multimedia Setups. *Applied Sciences*, 11(19), 8854. <https://doi.org/10.3390/app11198854>
- [15] Anheo, J., Robles, A., Martin, S. (2023). Internet of Things Remote Laboratory for MQTT Remote Experimentation. Proceedings of the 15th International Conference on Ubiquitous Computing & Ambient Intelligence. UCAMi 2023. *Lecture Notes in Networks and Systems*, 841. DOI: https://doi.org/10.1007/978-3-031-48590-9_16
- [16] Rocha, D., Teixeira, G., Vieira, E., Almeida, J., & Ferreira, J. (2023). A modular in-vehicle C-ITS architecture for sensor data collection, vehicular communications and cloud connectivity. *Sensors*, 23(3), 1724. DOI: <https://doi.org/10.3390/s23031724>
- [17] Knight, N., Kanza, S., Cruickshank, D., Brocklesby, W., & Frey, J. G. (2020). Talk2Lab: The smart lab of the future. *IEEE Internet of Things Journal*, 7 (9), 8631-8640. DOI: <https://doi.org/10.1109/JIOT.2020.2995323>
- [18] Villazon, A., Ormachea, O., Zenteno, A., Orellana, A. (2023). A Low-Cost Spectrometry Remote Laboratory. In: Auer, M.E., El-Seoud, S.A., Karam, O.H. Artificial Intelligence and Online Engineering. REV 2022. *Lecture Notes in Networks and Systems*, 524. Springer, Cham. DOI: https://doi.org/10.1007/978-3-031-17091-1_21
- [19] Caribo, O. F., Sibomana, L., Byungura, J. C., Asingwire, B. K., & Niyizamwiyitira, C. (2024). Digital Twins Applications in STEM Education: Challenges and Implementation Opportunities in Developing Countries. *IEEE Digital Education and MOOCs Conference (DEMOcon)*, 1-6. DOI: <https://doi.org/10.1109/DEMOcon63027.2024.10747951>
- [20] Park, E., Lim, J., Park, B. C., & Kim, D. (2021). IoT-Based Research Equipment Sharing System for Remotely Controlled Two-Photon Laser Scanning Microscopy. *Sensors*, 21(4), 1533. DOI: <https://doi.org/10.3390/s21041533>



Andriy Krupych was born in Lviv, Ukraine, on May 29, 1991. He received the B.S. (2012) and M.S. (2013) degrees in computer science at the Faculty of Applied Mathematics and Informatics, Ivan Franko National University of Lviv, Lviv, Ukraine. Currently PhD candidate at the Department of Radiophysics and Computer Technologies, Ivan Franko National University of Lviv. His research interests include optics, cloud and Internet of Things (IoT).



Pavlo Levush was born in Lviv, Ukraine, on July 12, 1999. He received the B.S. and M.S. degrees in computer science at the Faculty of Electronics and Computer Technologies, Ivan Franko National University of Lviv, Lviv, Ukraine, in 2021. His major field of study is computer science. He is currently an Assistant at the Department of Radiophysics and Computer Technologies, Ivan Franko National University of Lviv. His research interests include micro-processor systems, robotics, and the Internet of Things (IoT).